



**ZCC America**

# ZCC America

## CARBIDE MINING & CONSTRUCTION PRODUCTS

HEADQUARTERS:  
ZHUZHOU CEMENTED CARBIDE GROUP CO., LTD.  
ZHUZHOU CEMENTED CARBIDE WORKS IMP. & EXP. CO.

ZHUZHOU CEMENTED CARBIDE WORKS USA INC.  
ADD: 4651 PLATT LANE, ANN ARBOR, MICHIGAN 48108 USA  
TEL: +1(734)302-0125  
FAX: +1(734)302-0126  
EMAIL: [info@zccamerica.com](mailto:info@zccamerica.com)  
WEBSITE: [WWW.ZCCAMERICA.COM](http://WWW.ZCCAMERICA.COM)

2024 VERSION



# CONTENTS



ABOUT ZCC	01
PRODUCTION CAPACITY	03
R&D	05
QUALITY ASSURANCE	09

<b>CARBIDE BUTTONS</b>	13
<b>CARBIDE ENGINEERING BUTTONS</b>	21
<b>CARBIDE INSERTS</b>	27
<b>CARBIDE SUBSTRATES</b>	33
<b>CARBIDE STUDS FOR HPGR</b>	37
<b>CARBIDE INSERTS FOR TUNNEL BORING MACHINE TOOLINGS</b>	39



# ABOUT ZCC



Zhuzhou Cemented Carbide Group Co., LTD (ZCC), hailed as "the cradle of China's cemented carbide industry", is one of the 156 key projects constructed during the First Five-Year Plan. ZCC is a key enterprise of China Minmetals Corporation, one of the Fortune Global 500 companies. ZCC specializes in cemented carbides, which are known as "the teeth of industry" and are widely applied to military industry, aerospace, mechanical processing, metallurgy, petroleum drilling, mining tools, electronic communication, construction, among other fields.

ZCC is a leading enterprise in the cemented carbide industry with the largest production and sales scale in China. It is also a "world-class professional leading demonstration enterprise" awarded by China's State-owned Assets Supervision and Administration Commission of the State Council (SASAC). It is also a national manufacturing champion demonstration enterprise, a national technological innovation demonstration enterprise, a high-tech enterprise, and a national green factory.

## 1954

**FOUNDATION**

One of the 156 major projects that China constructed in 1954 in its "First Five-Year Plan"

## 1955

**THE FIRST CARBIDE INSERT**

China's 1st piece of cemented carbide insert was born in ZCC

## 2001

**FIRST INTRODUCTION OF HIP TECHNOLOGY**

The HIP technology was adopted for the first time in China, and the grade of YK05 was put into mass production

## 2004

**CEMENTED CARBIDE OUTPUT TO A HIGHER LEVEL**

China's 1st factory specializing in the production of carbide buttons

## 2017

**NEW BUSINESS DIVISION**

The original drill bit alloy plant and tungsten cobalt alloy plant to form a new business division specializing in the production of drilling cemented carbide

# PRODUCTION CAPACITY

Under ZCC, there are 8 professional production units: Profile Products Branch, Big Products Division, Drill Business Division, Special Products Division, Drilling and Tunneling Division, Powder Division, RTP Plant, and Mold Manufacturing Plant; as well as 4 wholly owned and holding subsidiaries: ZCC Cutting Tools Co., Ltd. (ZCC.CT), Jinzhou Cemented Carbide Co., Ltd. (Jinzhou), Zhuzhou Changjiang Carbide Tools Co., Ltd., and ZCC Works Imp.& Exp.Co., Ltd.

8 PROFESSIONAL PRODUCT DIVISIONS

3 R&D CENTERS

1 ANALYSIS AND TESTING CENTER

4 HOLDING SUBSIDIARIES





# R&D



ZCC's geo-mining alloys are mainly classified into four categories: Spherical buttons, Engineering bits, Substrate for PDC and TBM Inserts alloys, with an annual production capacity of 2,000 tons, and the cemented carbide products are widely used in different industries, such as energy, mining, exploration and infrastructure construction.

The flagship grades for ZCC's drilling alloys are YK05, YK05A, KD10, KD10H, etc. Among them, YK05 and KD10 are in the leading position in the domestic high-end market. YK05A and KD10A, as the new generation high-end carbide buttons products with independent intellectual property rights, have breakthrough the technological monopoly of international giants and are far ahead in product performance.





ZCC is in possession of the only national key laboratory of cemented carbide industry, one of the first batch of certified state-level enterprise technology centers, state-level analysis and testing center, and quality-control and technology-evaluation laboratory of industrial products (cemented carbides and other tungsten products). ZCC undertakes many of the the national "863" and "973" programs, national innovation capacity building programs, the national key technology R&D program, and national strategic innovative products and key new products project. The company has won the first and second prizes of national sci-tech progress, and the second prize of national invention.

Products of ZCC have been widely applied to the forefront of "Made in China 2025" and "the Belt and Road Initiative". Some typical achievements have solved the bottleneck problems of national industrial development. High-end cemented carbide products can be produced domestically, thus holistically promoting related industries.

The production technology of spiral tools for deep-hole drilling has led to the emergence of independent high-end cemented carbide processing tools in China's automotive industry. The development of cemented carbide roller rings for low-temperature rolling has enabled domestic rollers to be the preferred choice of steel enterprises. The industrial application enables PDC cemented carbide matrix to be a key material for energy extraction in deep/ultra deep wells with a depth of more than 3000 meters. Thanks to the production of ultra-fine diameter cemented carbides for micro drilling and milling, China's PCB processing is taking the lead globally.



# QUALITY ASSURANCE

ZCC always adheres to the quality policy of "laying emphasis on technology, being strict with management, and placing quality on top priority to meet customers' requirements with the Diamond brand". ZCC has acquired certificate of QHSE management system (quality, health and safety, and environment). ZCC has been adhering to the concept of "all for the customers" by respecting customers' requirements, and constantly improving technical and market services.





# OUR PROCESS

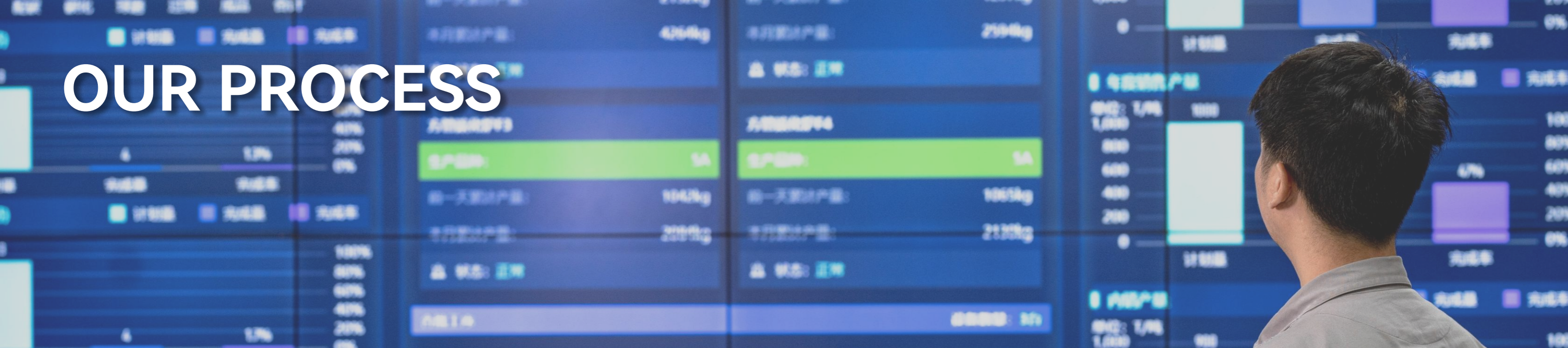

OIL FIELD



INFRASTRUCTURE



POWDER



FORMING



SINTERING



MINING



GEOLOGICAL PROSPECTING



MACHINING



INSPECTION



PACKAGING



# CARBIDE BUTTONS

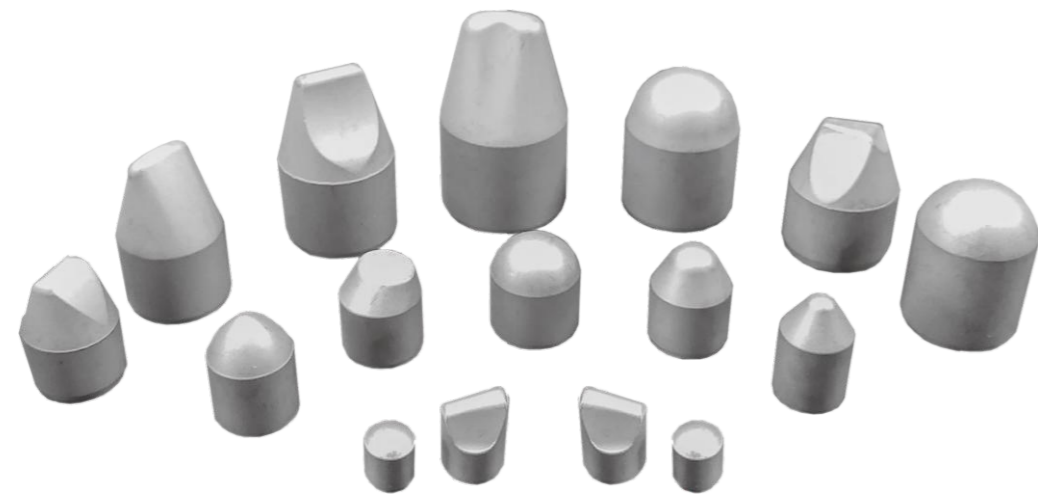

## CARBIDE BUTTONS FOR IMPACT DRILL BITS

Product Category	Grade	Co	Density	Hardness	TRS	Application area
		(%)	(g/cm <sup>3</sup> )	(HRA/HV3)	(N/mm <sup>2</sup> )	
Carbide buttons for high air pressure	YK05	6	14.94	1440	3000	The mainly popularized grade suitable for all kinds of cemented carbide post-button, showing good impact resistance and wear resistance, applicable to a wide range of rock stratum, and capable of providing a high drilling rate in soft and medium-hard rock strata drilling.
	KD10	6.15	14.90	1420	2900	The grade of new composite cemented carbide spherical button, showing high wear resistance and good crack propagation resistance at the same time, further improving the reliability and durability of spherical button products, suitable for all kinds of rock conditions, especially for hard rock stratum and rock stratum with large impact energy.
	KD20C	7	14.81	1400	3200	complementary grade, with an impact resistance better than that of YK05, suitable for hard rock stratum.
Carbide buttons for medium and low air pressure	KD10H	6	14.93	1410	2800	Suitable for medium and low air pressure DTH bits for drilling of medium and hard rock strata.
	KD10B	6.5	14.88	1390	2900	Suitable for medium and low air pressure DTH bit, showing good toughness, applicable to the drilling of medium and hard rock strata and conglomerate rock.
	KD30D	8	14.71	1310	3000	Suitable for welding drill bit applicable to the drilling of rock stratum of medium hardness and above.
Carbide buttons for high air pressure	YK05A	6	14.90	1520	2800	Special for DTH & TOP HAMMER Bits, as well as for wear parts.
	KD10A	6	14.92	1580	2800	Special for DTH & TOP HAMMER Bits, as well as for wear parts.



# CARBIDE BUTTONS FOR TRI-CONE DRILL BITS

Product Category	Grade	Co	Density	Hardness	TRS	Application area
		(%)	(g/cm <sup>3</sup> )	(HRA/HV3)	(N/mm <sup>2</sup> )	
Carbide buttons for mining tri-cone drillbits	KD30	10	14.51	88.5	3300	Suitable for assembling mining tri-cone drill bits with both high wear resistance and toughness.
	KD40E	10	14.5	87.6	2900	Suitable for assembling mining tri-cone drill bits.
	YG11C	11.5	14.36	87.2	3000	Suitable for assembling mining tri-cone drill bits, used in medium to hard rock formations.
Carbide buttons for oil field tri-cone drillbits	YG13C	13	14.22	86.7	3000	Suitable for assembling mining tri-cone drill bits, used in medium to hard rock formations.
	KD10F	6	14.92	90.8	2670	Suitable for assembling mining tri-cone drill bits.
	KD30F	11	14.43	88.8	2600	Suitable for assembling mining tri-cone drill bits.
	KD40F	10	14.53	88.1	2840	Suitable for assembling mining tri-cone drill bits.
	KD60F	12	14.30	86.2	2520	Suitable for assembling mining tri-cone drill bits.
	KD60C	12	14.30	85.5	2400	Suitable for assembling mining tri-cone drill bits.
	KD50C	14	14.12	86.1	2430	Suitable for assembling mining tri-cone drill bits.
KD60D	16	13.90	83.8	2350	Suitable for assembling mining tri-cone drill bits.	

## CODE KEY FOR TYPES OF BUTTONS

Buttons are divided into the following 8 categories based on the shape of the top part

**Q** Spherical      **Z** Conical      **D** Parabolic      **P** Flat top  
**T** Flat cone      **X** Wedged      **B** Side wedged      **S** Spoon

The types of buttons are indicated with capital letters "s" or "y" and the letter indicating the shape of the top part plus numerals.

<b>(G)</b>	<b>S</b>	<b>Q</b>	<b>18</b>	<b>26 - E</b>	<b>15</b>	<b>Q / A</b>
①	②	③	④	⑤	⑥	⑦ ⑧ ⑨
<b>(G)</b>	<b>Y</b>	<b>Z</b>	<b>18.2</b>	<b>25 - X</b>	<b>12</b>	<b>Q / A</b>

① Finish grinding

② Specification of series: "s" indicates the series of imported cemented carbide buttons with their dimensional specifications and "y" indicates the series of cemented carbide buttons in accordance with the dimensional specifications specified by customers.

③ It indicates the shape of the top part of the buttons See I above.

④ It indicates the diameter of the buttons in mm. Only 2-digit integers are to be taken and zero is added before the integer if there is only 1 digit.

⑤ It indicates the height of the button in mm. Only 2-digit integers are to be taken and a zero is added before one integer if there is only 1 digit.

⑥ It indicates the angle of the chamfered bottom of the button.

E- The included angle in relation to the axle center line is 15-18 degrees;

F- The included angle in relation to the axle center line is 30 degrees ( Exceptional example: F2 indicates 0.7×30%);

G- The included angle in relation to the axle center line is 45 degrees;

X- The included angle in relation to the axle center line is other values or other bottom shapes.

⑦ It indicates the height of the bottom chamfer and numerals are 10 times that of height in mm and zero is added before the integer if there is only 1 digit.

⑧ It indicates the status of the gas containing hole at the bottom of the button.

Q-Spherical hole, Z-Conical hole, J- Sharp hole, No letter here if there is no hole.

⑨ Code for non-standard product, to be set by manufacturer as needed.

Note: If Digit 5 and Digit 6 are both defaulted, it means a post-button product with double chamfers.

## Tolerances For Diameters And Heights of Buttons

Diameter (D)		Height (H)	
Nominal size	Allowed tolerance	Nominal size	Allowed tolerance
≤10	+0.10	≤11	±0.10
		11~18	±0.15
>10	+0.15	18~25	±0.15
		>25	±0.20



## Q TYPES (SPHERICAL)

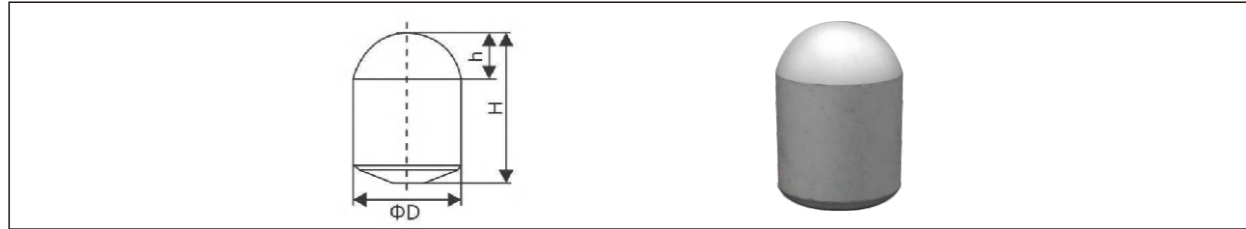

Type	Basic dimensions		
	D	H	h
SQ0812	8.25	12.30	2.67
SQ1015	10.25	15.00	3.31
SQ1217	12.35	17.10	4.07
SQ1420	14.35	20.00	4.71
SQ1621	16.35	21.00	5.35
SQ1826	18.35	26.10	7.81
SQ1928	19.35	28.50	8.07
SQ2028	20.50	28.00	7.61
SQ2230	22.25	30.12	9.20
SQ2435	24.35	35.00	10.39
SQ2536	25.50	36.00	10.90

The dimensions and shapes can be customized according to the customer's requirements.  
The product can be used on impact bits for rock drilling, DTH bits, tri-cone drill bits, and is applicable to the drilling of extremely hard rock stratum.

## D TYPES (PARABOLIC)

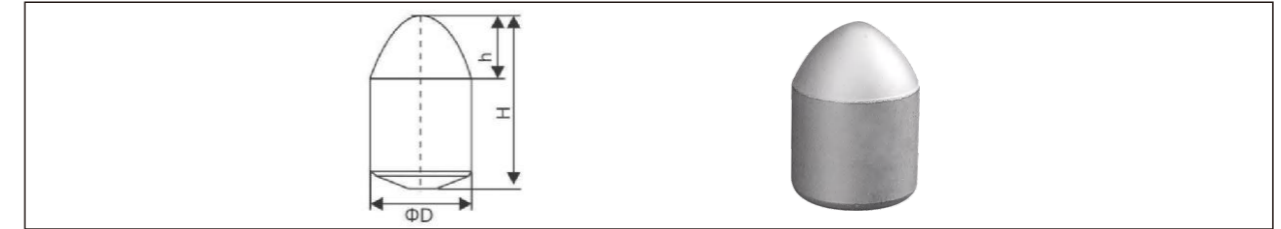

Type	Basic dimensions		
	D	H	h
SD0711	7.25	11.00	3.93
SD0913	9.25	13.00	5.00
SD1117	11.30	17.00	6.13
SD1218	12.35	18.00	7.60
SD1422	14.35	22.00	7.40
SD1625	16.33	24.60	9.77
SD1829	18.25	29.00	10.44
SD1930	19.22	30.00	9.95
SD2032	20.28	32.12	12.50
SD2233	22.31	33.00	12.76

The dimensions and shapes can be customized according to the customer's requirements.  
The product can be used on DTH bits, tri-cone drill bits, and is applicable to the drilling of middle hard rock stratum.

## Z TYPES (CONICAL)

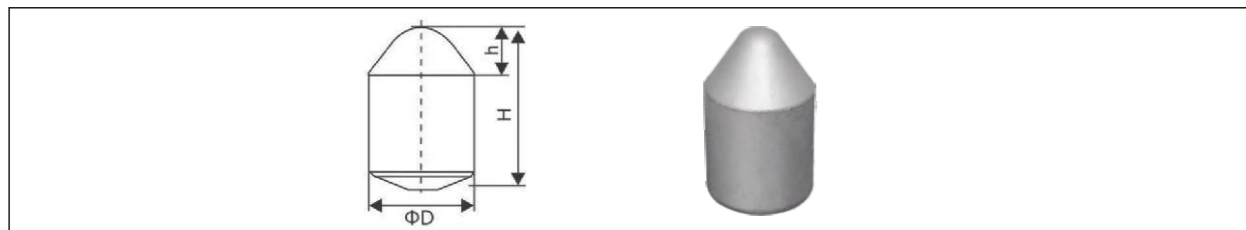

Type	Basic dimensions		
	D	H	h
SZ0812	8.25	12.20	3.52
SZ1016	10.25	16.30	5.22
SZ1320	13.35	22.20	5.85
SZ1424	14.38	24.00	8.27
SZ1520	15.00	20.00	8.91
SZ1625	16.30	25.00	8.80
SZ1828	18.25	28.00	10.14
SZ1925	19.00	25.00	6.50
SZ2536	25.77	36.00	18.45

The dimensions and shapes can be customized according to the customer's requirements.  
The product can be used on impact bits for rock drilling, DTH bits, tri-cone drill bits, and is applicable to the drilling of extremely hard rock stratum.

## X TYPES (WEDGED)

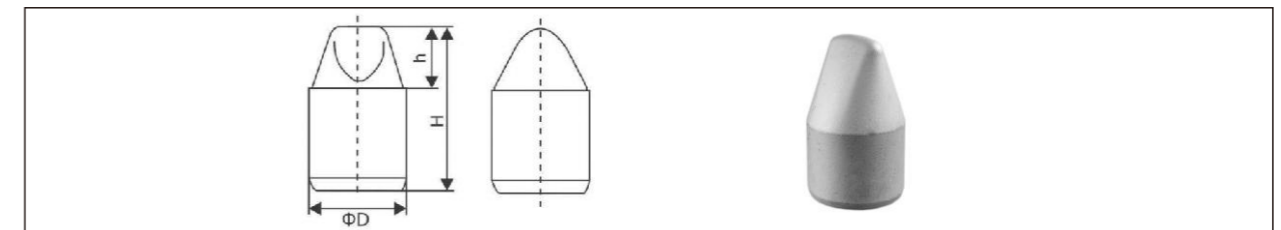

Type	Basic dimensions		
	D	H	h
SX1014-E18	10.37	14.00	6.00
SX1318-E17Z	13.15	18.00	7.50
SX1418A-E20	14.30	18.00	8.00
SX1620A-E20	16.35	19.50	10.00
SX1724-E18Z	17.20	24.00	11.50
SX1827-E19	18.37	27.00	12.00
SX2236	22.47	36.00	18.00

The dimensions and shapes can be customized according to the customer's requirements.  
The product can be used on special-shaped DTH bits, tri-cone drill bits and is applicable to the high-speed drilling of soft rock stratum with a low probability of button breakage.



## B TYPES (SIDE WEDGED)

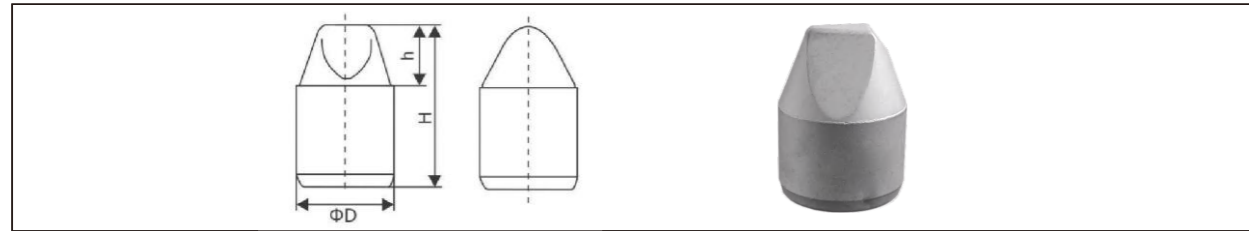

Type	Basic dimensions		
	D	H	h
SB1215A-E15	12.35	15.00	6.00
SB1418-E18	14.37	18.00	5.50
SB1419-E14Q	14.30	19.60	8.40
SB1620-E19	16.37	20.60	7.20
SB1825-E20Q	18.25	25.20	10.80
SB1924-E21	19.375	24.05	9.05
SB2333B-E22	23.37	33.50	15.00
SB2941	28.90	42.00	20.91

The dimensions and shapes can be customized according to the customer's requirements.

## S TYPES (SPOON)

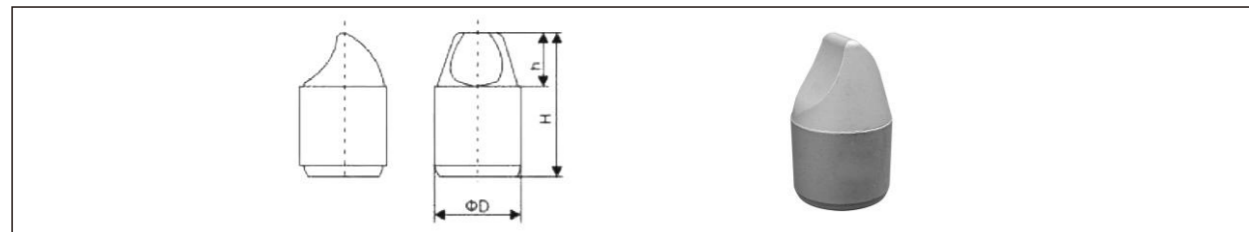

Type	Basic dimensions		
	D	H	h
SS1418-E20	14.30	18.00	8.10
SS1620-E20	16.35	19.50	11.10
SS2444-E22	24.37	44.00	22.00

The dimensions and shapes can be customized according to the customer's requirements.  
The product can be used on tri-cone drill bits and is applicable to the high-speed drilling of soft rock stratum;

## P TYPES (FLAT TOP)

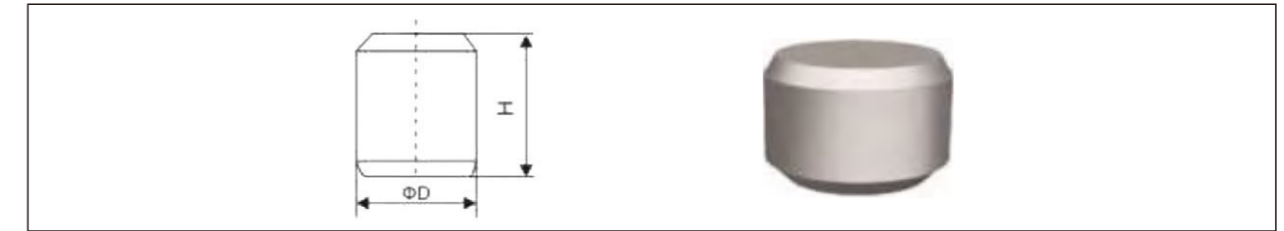

Type	Basic dimensions	
	D	H
SP0807-E15	8.25	6.90
SP1010-E20	10.35	10.00
SP1212-E18	12.37	12.00
SP1515-G15	15.00	15.00

The dimensions and shapes can be customized according to the customer's requirements.  
The product can be used on tri-cone drill bits, diamond bits, and hole stabilizers, etc. to reduce the wear of friction surface.

## SERRATED INSERTS

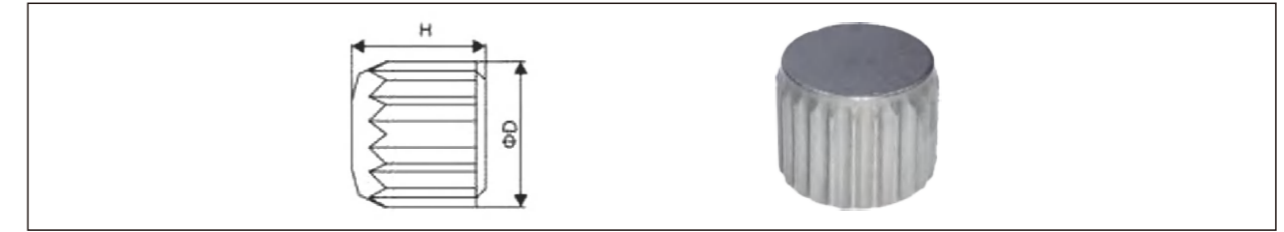

Type	Basic dimensions	
	D	H
YP08.107-F	8.17	7.40
YP9.708-F	9.75	8.00
YP14.813-F	14.80	13.7

The dimensions and shapes can be customized according to the customer's requirements.

# CARBIDE ENGINEERING BUTTONS



## CARBIDE ENGINEERING BUTTONS FOR EXCAVATING TOOLS

Product Category	Grade	Co	Density	Hardness	TRS	Application area
		(%)	(g/cm <sup>3</sup> )	(HRA/HV3)	(N/mm <sup>2</sup> )	
For pavement milling inserts	KC30	6	14.93	87.5	2200	Milling of asphalt pavement and cement stabilized base.
	KC35	6	14.93	88.1	2300	Milling of cement pavement.
	KC60	10	14.49	85.8	2300	Rotary excavating under general working conditions.
For excavation and Wear-resistant accessories	KC55	9	14.60	86.6	2400	Rotary excavating of intact medium-hard rock stratum.
	KW60	8.5	14.65	85.3	1950	Rotary excavating in complex hard rock stratum.
	KW55	5.5	86.50	14.93	1600	Suitable for coal mining and roadway excavation under complex working conditions of super hard rock.
	YG11C	11.5	14.36	87.0	3000	Requiring engineering accessories with high wear resistance.
	YG13C	13	14.22	86.3	3000	Wear-resistant and impact-resistant engineering accessories for bits of small tunneling and horizontal directional drills.
	YG15C	15	14.02	85.7	2900	Engineering accessories for casing drill bits and double-wheel milling plate teeth.

## CODE KEY FOR TYPES OF ENGINEERING BUTTONS

Model designation

<b>Y</b>	<b>J</b>	<b>16.0</b>	<b>26 - X</b>	<b>10</b>	<b>Q</b>
①	②	③	④ ⑤	⑥	⑦



# PAVEMENT MILLING BUTTONS

①Series type: "S" refers to regular models, "Y" indicates cemented carbide engineering button series customized according to the dimensional requirements specified by customers, and "X" refers to the cemented carbide pavement milling product series.

②Indication: Type J - engineering button, Type L - pavement asphalt milling series, Type S - cement pavement milling series.

③Engineering button diameter in mm: expressed by two integers with one decimal, with "0" in the front in case of less than two integers.

④Engineering button height in mm: two integers only, with "0" in the front in case of less than two integers.

⑤Chamfer angle at the bottom of the engineering buttons.

E - an included angle of 15° or 18° with the axis.

F - an included angle of 30° with the axis.

G - an included angle of 45° with the axis.

X - an included angle of other values with the axis, or other bottom shapes.



⑥Chamfer height at the bottom of the engineering button, expressed by a number 10 times the height (in mm), and with "0" in the front in case of less than two digits.

⑦Air hole at the bottom of the engineering buttons.

Q - spherical hole, using default value when there is no air hole.

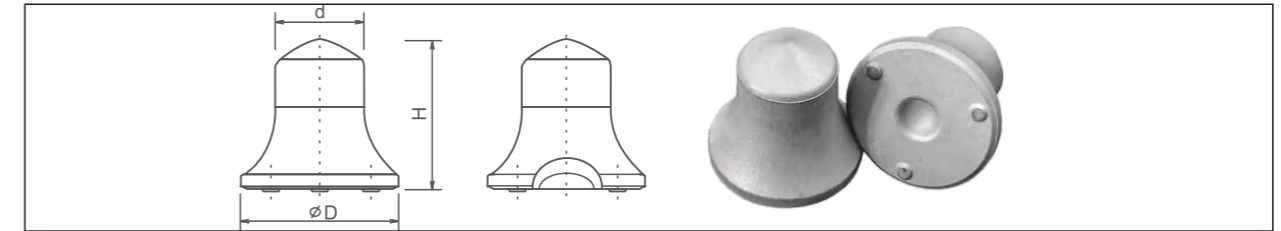

Type	Basic dimensions		
	D	H	d
YJ15.615	15.60	15.00	8.50
YJ16.016	16.00	16.50	8.50
YJ17.517	17.50	17.00	9.50
YJ18.417	18.40	17.30	10.50
YJ18.817	18.80	17.50	10.50
YJ19.018	19.00	18.00	11.50
YJ19.518	19.00	17.50	11.50
YJ20.020	20.00	19.50	11.50
YJ20.420	20.40	20.30	11.00
YJ20.620	20.60	19.50	11.70
YJ20.820	20.80	19.80	11.70
YJ22.023	22.00	23.00	11.50

The dimensions and shapes can be customized according to the customer's requirements.



Type	Basic dimensions	
	D	H
YJ12.018	12.00	18.00
YJ12.724	12.70	24.50
YJ13.024	13.00	24.50
YJ13.025	13.00	25.00
YJ13.425	13.40	25.00
YJ14.025	14.00	25.00
YJ15.326	15.30	26.50

The dimensions and shapes can be customized according to the customer's requirements.

# ENGINEERING ROTARY EXCAVATING BUTTONS

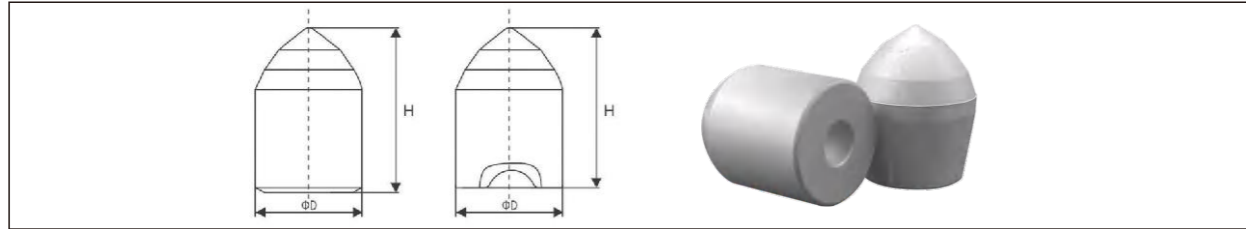

Type	Basic dimensions	
	D	H
YJ17.023	17.00	23.00
YJ18.024	18.00	24.00
YJ19.025	19.00	25.00
YJ20.026	20.00	26.00
YJ20.527	20.50	27.00
YJ21.027	21.00	27.00
YJ22.028	22.00	28.00
YJ23.530	23.50	30.00
YJ24.032	24.00	32.00
W25031	25.00	31.00
YJ25.532	25.50	32.00
YJ28.035	28.00	35.00
Y29.5036	29.50	36.00
YJ30.038	30.00	38.00

The dimensions and shapes can be customized according to the customer's requirements.

# MINING BUTTONS

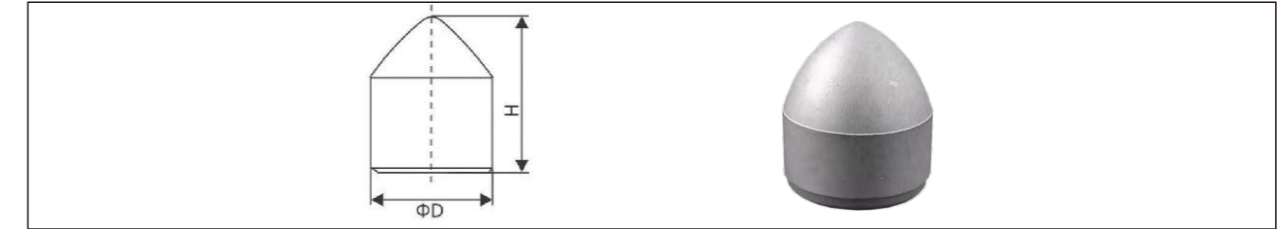

Type	Basic dimensions	
	D	H
YJ16.026	16.00	26.00
YJ17.030	17.00	30.00
Y19.032	19.00	19.00
YJ20.032	20.00	32.00
YJ22.034	22.00	34.00
YJ25.040	25.00	40.00
Y27.036	27.00	36.00
YJ30.044	30.00	44.00

The dimensions and shapes can be customized according to the customer's requirements.

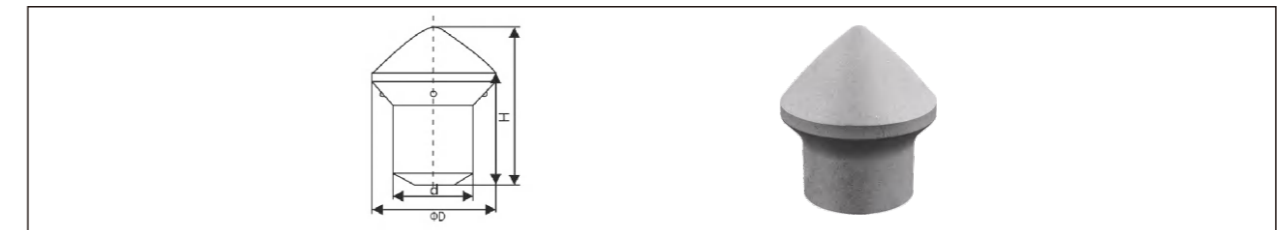

Type	Basic dimensions		
	D	H	d
YJ18.533	18.50	33.00	12.00
YJ20.025	20.00	25.00	15.00
YJ22.028	22.00	28.00	14.00
YJ24.934	24.90	34.00	17.20
YJ25.028	25.00	28.00	20.00
YJ30.035	30.00	35.00	24.50
YJ33.039	33.00	39.00	24.60
YJ35.045	35.00	45.00	28.40

The dimensions and shapes can be customized according to the customer's requirements.



# CARBIDE INSERTS

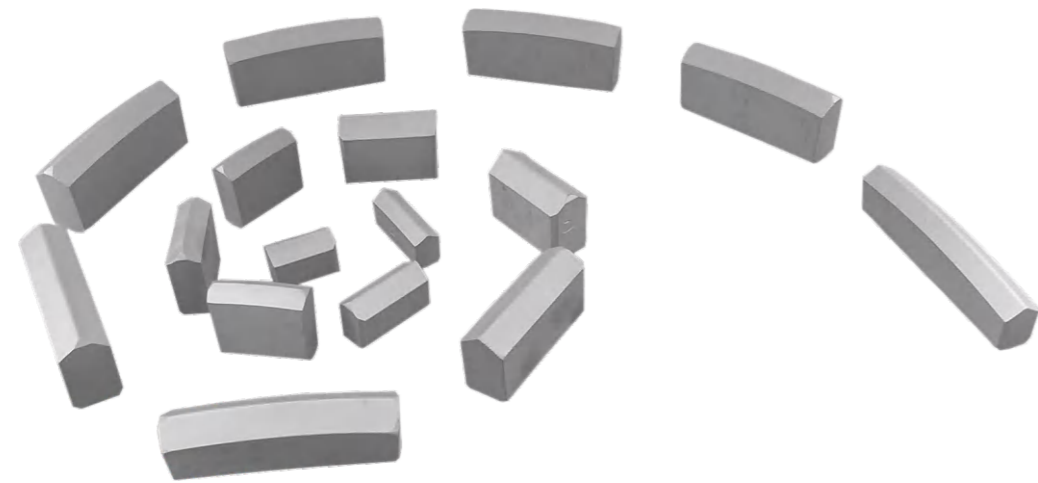

## CARBIDE INSERTS FOR MINING TOOLS

Product Category	Grade	Co	Density	Hardness	TRS	Application area
		(%)	(g/cm <sup>3</sup> )	(HRA/HV3)	(N/mm <sup>2</sup> )	
Brazing Sheet	YK15.6	9	14.61	87.7	2800	Suitable on impact rotary rock drill bit for medium-duty rock drills, applicable to the drilling of medium-hard and hard rock strata with f=14-15.
	YK20	10	14.52	87.2	2900	Suitable on impact rotary rock drill bit for medium-duty rock drills, applicable to the drilling of comparatively hard and hard rock strata with f=15-18.
	YG11C	11.5	11.36	87.2	3000	Suitable on impact rotary rock drill bit for heavy-duty rock drills, applicable to the drilling of hard rock strata with f=18 or above.

## CARBIDE INSERTS FOR GEOLOGICAL PROSPECTING

Product Category	Grade	Co	Density	Hardness	TRS	Application area
		(%)	(g/cm <sup>3</sup> )	(HRA/HV3)	(N/mm <sup>2</sup> )	
Carbide inserts for Geotogital Exploration	Yg6	6	14.95	90.5	2700	Suitable on electric coal drill bits for the drilling of coal and anthracite beds without pyrite and the drilling of schist, sylvite, rock salt, and other similar strata without silicification.
	Yg8	7.8	14.76	89.8	3000	Suitable on core bits, oil well bits, and drag bits for geological exploration, applicable to the drilling of soft rocks and coal beds with f=8 or below, and also to the natural stone processing and concrete drilling.
	YG8C	8.3	14.7	88.5	2900	Suitable on cutting pick bits for the drilling of rocks with f=14 and below and coal beds containing hard rocks, and on the impact bits for the drilling of hard rocks.

# BRAZING SHEETS ARE DIVIDED INTO TWO CATEGORIES

**Type KAP** straight brazing sheet

**Type KBP** cross brazing sheet

**KA P 40\* 13\* 9.5 B/ XJ**  
 ① ② ③ ④ ⑤ ⑥ ⑦

①Series type: "KA" refers to the sheets for straight cemented carbide bits, and "KB" refers to the sheets for cross or X cemented carbide bits;

②Code of roughcast information;

③Brazing sheet length, in mm;

④Brazing sheet height, in mm;

⑤Brazing sheet thickness, in mm;

⑥No chamfering;

⑦Product information.

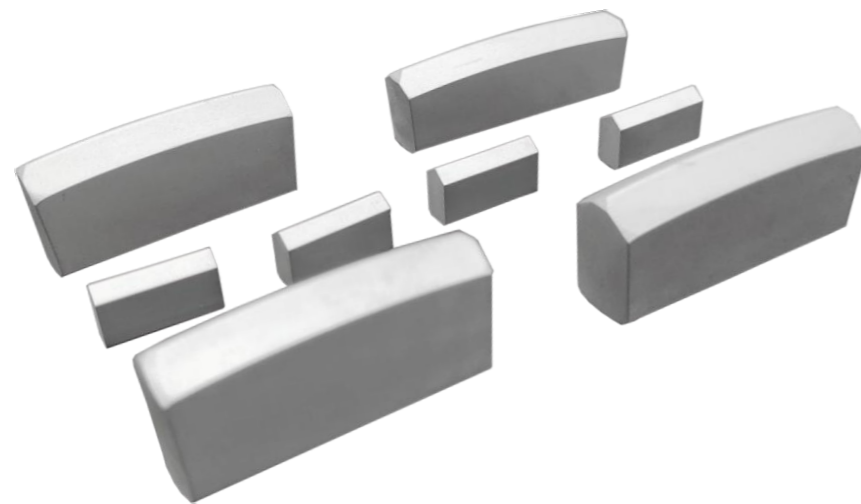

## STRAIGHT BRAZING SHEET

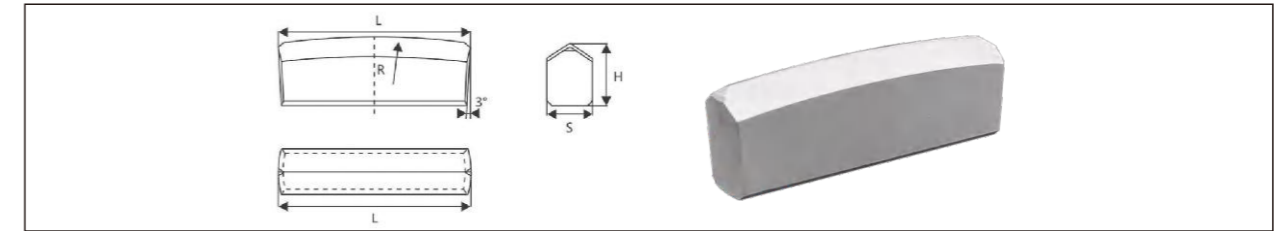

Type	Basic dimensions		
	L	H	S
KAP20*10.5*6.5	20.00	10.50	6.50
KAP40*12.7*9.7	40.00	12.70	9.70
KAP40*13*9.2T	40.00	13.00	9.20
KAP40*13*9.5	40.00	13.00	9.50
KAP42*13.3*9	42.00	13.00	9.00

The dimensions and shapes can be customized according to the customer's requirements.

## CROSS BRAZING SHEET

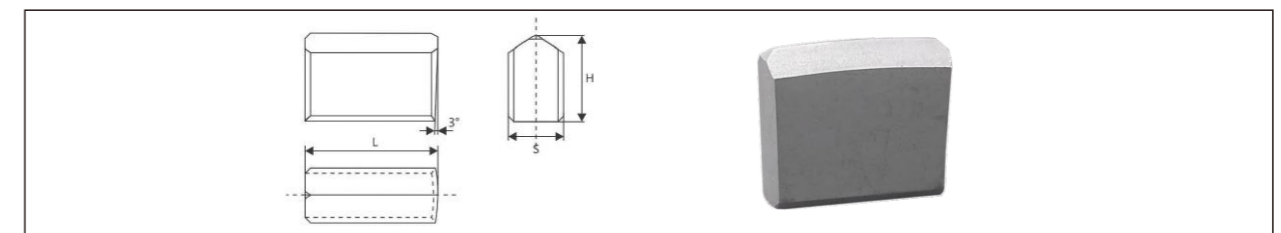

Type	Basic dimensions		
	L	H	S
KBP14*10*8	14.00	10.00	8.00
KBP24*16*10	24.00	16.00	10.00
KBP37*8*7.2	37.00	7.20	8.00

The dimensions and shapes can be customized according to the customer's requirements.



## T21, FOR CORE BITS FOR COMPARATIVELY HARD ROCK STRATUM DRILLING

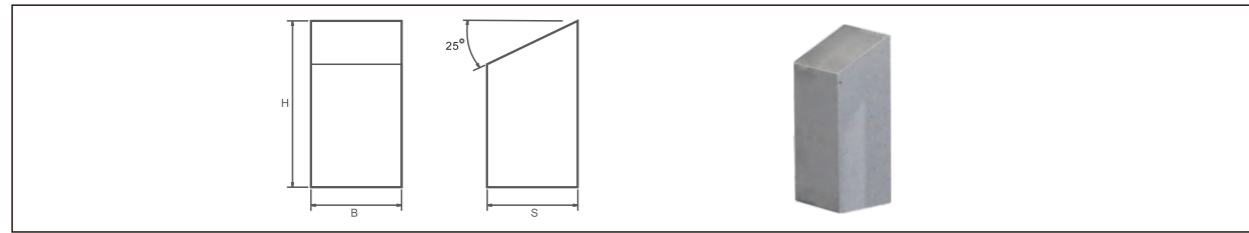

Type	Basic dimensions		
	L	H	S
T2105C	5.00	13.00	5.00
T2107	7.50	10.00	3.00
T2108	8.50	8.00	3.00
T2110	10.00	14.00	4.00

The dimensions and shapes can be customized according to the customer's requirements.

## TWP, FOR DRILL BITS FOR ROTARY DRILLING OF COAL BEDS AND SOFT ROCK STRATUM

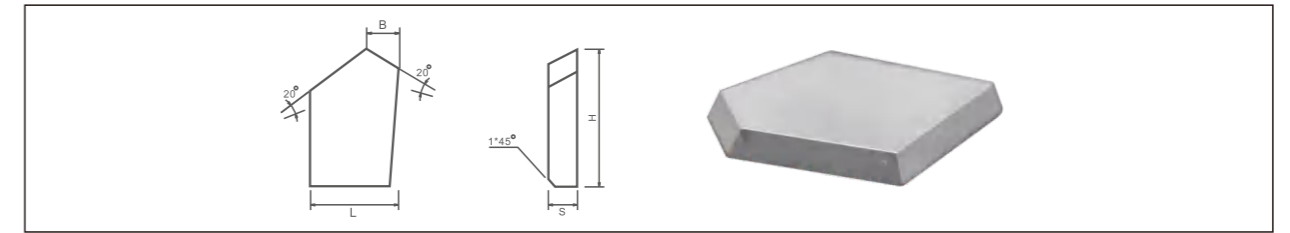

Type	Basic dimensions		
	B	H	S
TWP121173	5.00	19.00	3.00
TWP121174	5.00	19.00	3.00
TWP133002	5.00	22.00	3.00
TWP133003	5.00	22.00	3.00
TWP143004	5.00	20.00	2.30
TWP143005	5.00	20.00	2.30

The dimensions and shapes can be customized according to the customer's requirements.

## T30, FOR CORE BITS FOR HARD ROCK STRATUM DRILLING

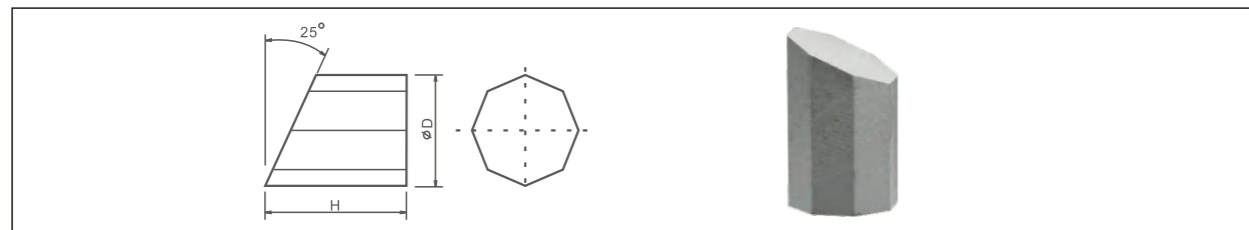

Type	Basic dimensions	
	D	H
T3005	5.00	10.00
T3007	7.00	10.00
T3010	10.00	16.00

The dimensions and shapes can be customized according to the customer's requirements.

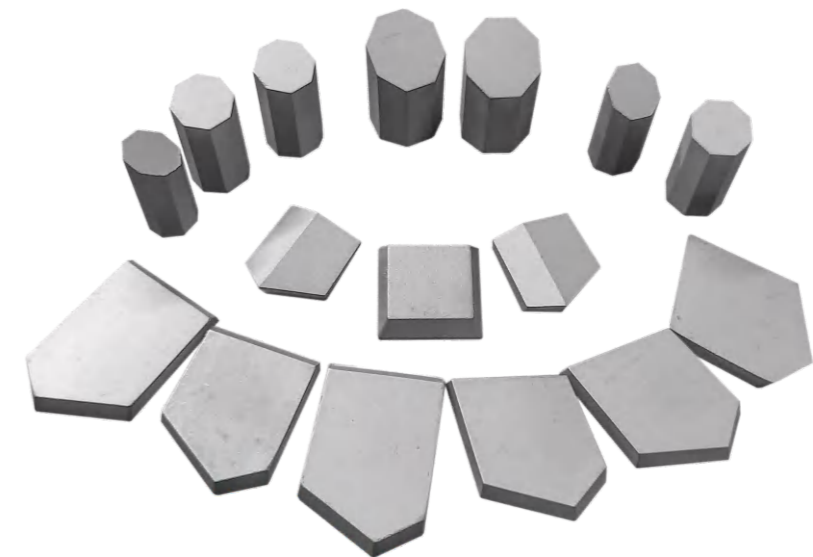

# CARBIDE SUBSTRATES

## CARBIDE SUBSTRATES FOR PDC BITS

Product Category	Grade	Co	Density	Hardness	TRS	Application area
		(%)	(g/cm <sup>3</sup> )	(HRA/HV3)	(N/mm <sup>2</sup> )	
Carbide substrate for cutting and oil	KE20	13	14.26	88.6	3500	The mainly popularized grade, suitable for the diamond composite sheet substrate for oil fields and cutting.
	YK10.1	11.5	14.41	88.5	3300	Suitable for the diamond composite sheet substrate for oil fields and cutting.
	KE25A	8	14.71	88.9	3140	Suitable for the diamond composite sheet substrate for oil fields and cutting.
	KD30	10	14.51	88.4	3130	Suitable for the diamond composite sheet substrate for oil fields and cutting.
Carbide substrate for mines	KE65	16.5	113.88	85.2	2900	The mainly popularized grade, suitable for the diamond composite sheet substrate for mines.



## GRID SUBSTRATES

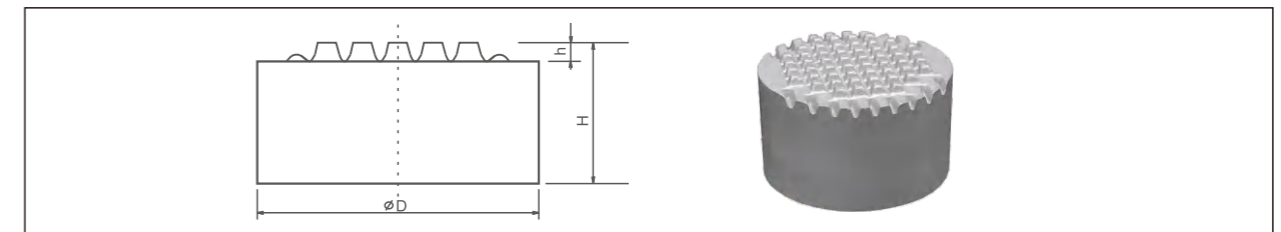

Type	Basic dimensions		
	D	H	h
ZFP9.25x7.6W	9.25	7.6	0.6
ZFP11.35x7.0W	11.35	7.0	0.6
ZFP14.7x12.5W	14.70	12.5	1.0
ZFP15.0x12.2W	15.00	12.2	0.55
ZFP18.0x12.5W	18.00	12.5	1.0
ZFP20.9x15.8W	20.90	15.8	1.0
ZFP23.6x12.5W	23.60	18.0	0.5
ZFP34.2x17.8W8	24.40	17.9	0.55

The dimensions and shapes can be customized according to the customer's requirements. It is suitable for the diamond composite sheet substrate.



## LINEAR SUBSTRATES

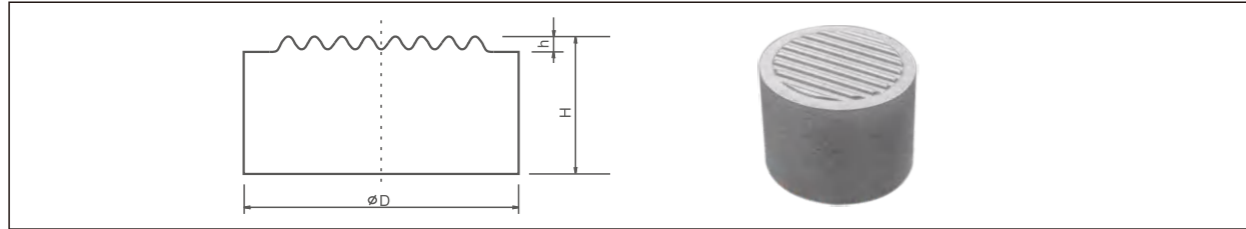

Type	Basic dimensions		
	D	H	h
ZFP14.6x4.2Z2	14.60	4.2	1.8
ZFP14.6x12.5Z2	14.60	12.5	1.8
ZFP18.0x12.9Z	18.00	12.9	0.6
ZFP20.3x8.3Z5	20.70	8.3	1.6
ZFP37.2x5.0Z1	37.45	4.0	0.32

The dimensions and shapes can be customized according to the customer's requirements.

## PLANAR SUBSTRATES

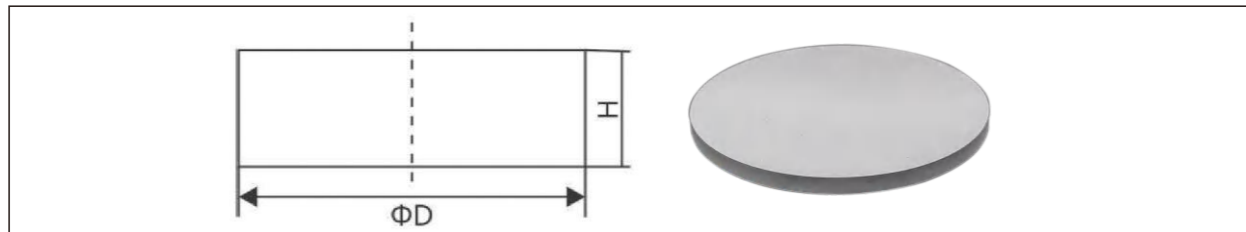

Type	Basic dimensions	
	D	H
ZFP9.5x7.8P	9.5	7.6
ZFP11.0x5.5P	11.0	5.5
ZFP13.7x3.8P	13.7	3.8
ZFP14.6x4.1P	14.6	4.1
ZFP15.5x4.0P	15.5	4.0
ZFP33.9x7.0P	33.9	7.0
ZFP45.0x3.9P	45	3.9
ZFP55.0x3.5P	55	3.5
ZFP62.0x3.5P	62	3.5
ZFP64.6x3.5P	64.6	3.5
ZFP77.4x6.0P	77.4	6.0

The dimensions and shapes can be customized according to the customer's requirements.

## RADIAL SUBSTRATES

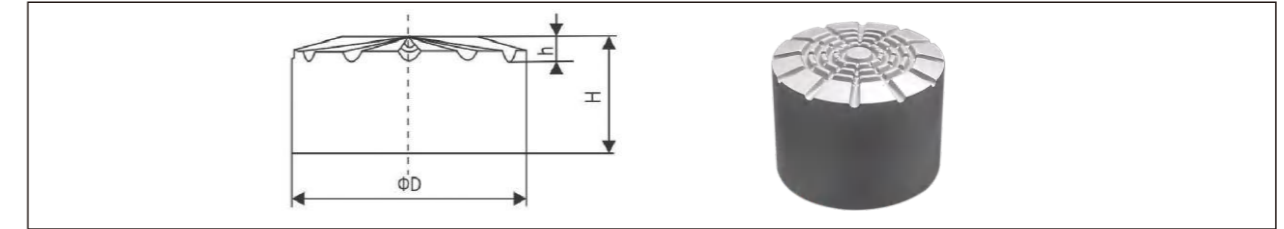

Type	Basic dimensions		
	D	H	h
ZFP14.6x4.8F	14.60	4.8	1.6
ZFP14.6x7.5F	14.60	7.5	1.6
ZFP16.76x12.0F	16.76	12.0	1.6
ZFP21.0x7.8F1	21.00	7.8	1.6

The dimensions and shapes can be customized according to the customer's requirements.

## ANNULAR SUBSTRATES

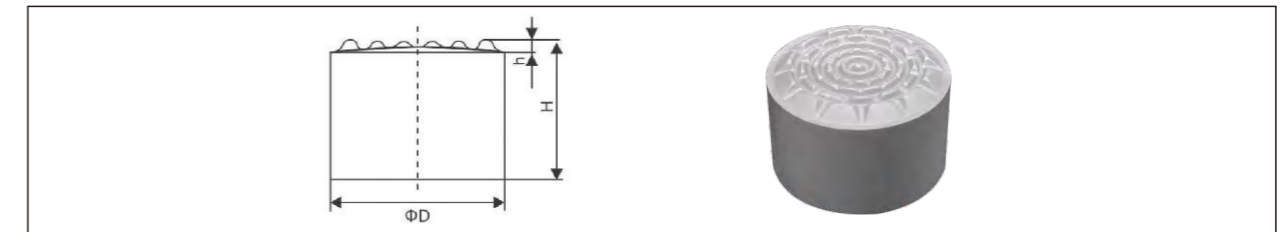

Type	Basic dimensions		
	D	H	h
ZFP15.0x12.2H2	15.1	12.3	0.863
ZFP17.65x12.5HL	17.75	12.6	0.7
ZFP17.8x12.2H	17.9	12.3	1.024

The dimensions and shapes can be customized according to the customer's requirements.

## SPECIAL SHAPE SUBSTRATES

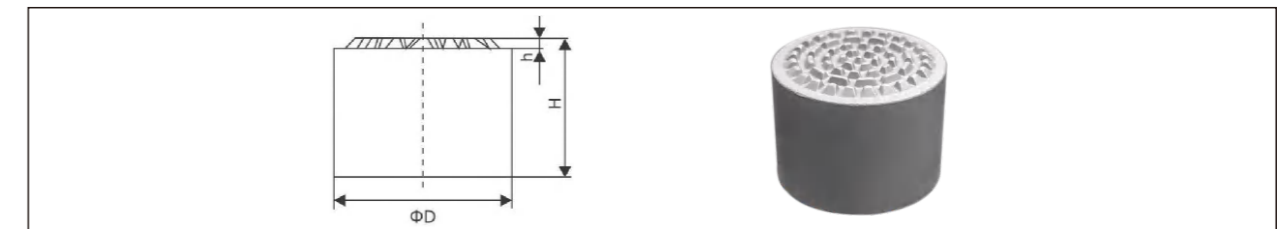

Type	Basic dimensions		
	D	H	h
ZFP14.7x12.5S	14.7	12.5	0.9
ZFP14.8x12.5S1	14.8	12.5	1.0
ZFP18.0x12.5S1	18.0	12.5	1.0
ZFP21.0x12.8S3	21.1	12.8	1.0

The dimensions and shapes can be customized according to the customer's requirements.

# CARBIDE STUDS FOR HPGR

## CARBIDE STUDS FOR HPGR



Product Category	Grade	Co	Density	Hardness	TRS	Recommended applications
		(%)	(g/cm <sup>3</sup> )	(HRA/HV3)	(N/mm <sup>2</sup> )	
Carbide Studs	YG11	11	14.43	88.0	3200	Suitable for crushing iron ore, steelslag and pebbles.
	KZ35	15	13.95	88.0	3500	Suitable for crushing and fine grinding of iron ore and sintered agglomerates.
	YG15	14.9	14.05	87.0	3300	Suitable for occasions where the size of the pressure roller is large and bears a large load.
	KZ45	18	13.79	87.0	3400	Suitable for crushing cement raw meal, clinkel, mixture, bauxite.
	YG15C	15	14.02	85.5	2900	Suitable for crushing cement mixture, steel slag, iron ore, bauxite.
	Yg20	20	13.56	85.0	3400	Suitable for crushing raw cement, steel slag and mixture.

## TYPES OF CARBIDE STUDS FOR HPGR



Type	D		H	
	Basic dimensions	Allowed tolerance	Basic dimensions	Allowed tolerance
LWG095569	16	-0.06~-0.04	40	±0.2
LWG095568	16	-0.06~-0.04	45	±0.2



Type	D		H	
	Basic dimensions	Allowed tolerance	Basic dimensions	Allowed tolerance
LWG125141	16.55	±0.009	36	±0.2
LWG125142	17.05	±0.01	40	±0.2



## TYPES OF CARBIDE STUDS FOR HPGR

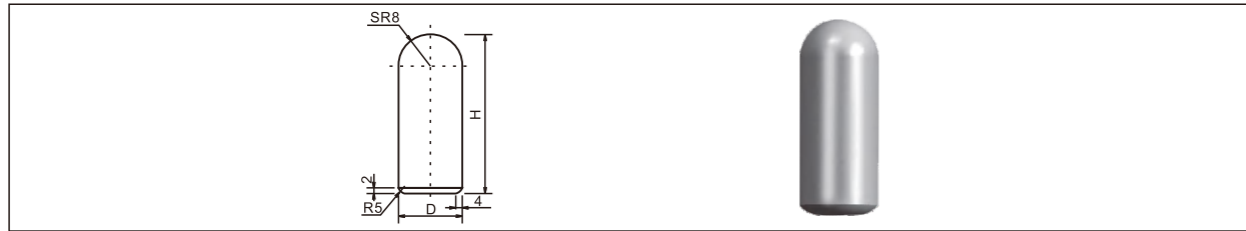

Type	D		H	
	Basic dimensions	Allowed tolerance	Basic dimensions	Allowed tolerance
LWG125101	16	-0.06~-0.04	40	-0.5~0
LWG125102	16	-0.06~-0.04	45	-0.5~0



Type	D		H	
	Basic dimensions	Allowed tolerance	Basic dimensions	Allowed tolerance
LWG115161	20	-0.04~0.02	40	±0.2

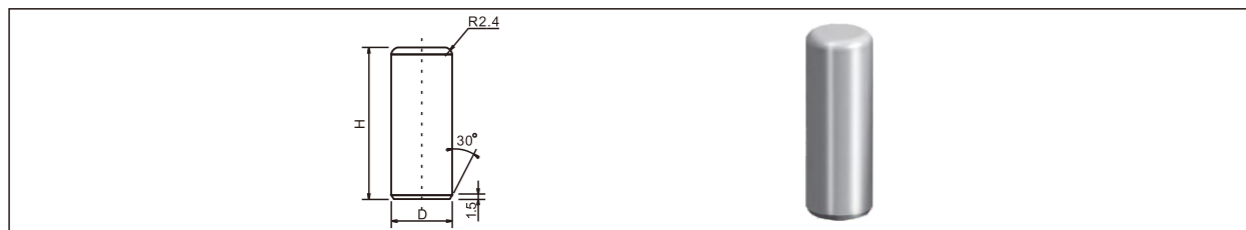

Type	D		H	
	Basic dimensions	Allowed tolerance	Basic dimensions	Allowed tolerance
LWG135050	16	-0.06~-0.04	45	±0.2



Type	D		H	
	Basic dimensions	Allowed tolerance	Basic dimensions	Allowed tolerance
LWG125087	15	±0.046~+0.028	30	±0.1

More types are available on request.

# CARBIDE INSERTS

## FOR TUNNEL BORING MACHINE TOOLINGS

### SELECTION OF MATERIAL GRADES FOR THE TOOLINGS

Different material grades for toothed toolings ( scrapers ) are selected based on the different geological conditions and the performances of the toolings on the tool body. There is a wide range of grades for excavating applications developed by the corporation for customers to choose. Listed below are only the properties of some conventional grades for tunnel boring machine toolings.

Product Category	Grade	Co	Density	Hardness	TRS	Application area
		(%)	(g/cm <sup>3</sup> )	(HRA/HV3)	(N/mm <sup>2</sup> )	
Carbide Studs	YG8	7.8	14.74	89.0	≥2350	For making inserts for rock drilling bits and excavating tools.
	YG11C	11.3	14.40	86.5	≥2260	
	YG13C	13	14.35	85.5	≥2500	

# TUNNEL BORING MACHINE TOOLINGS

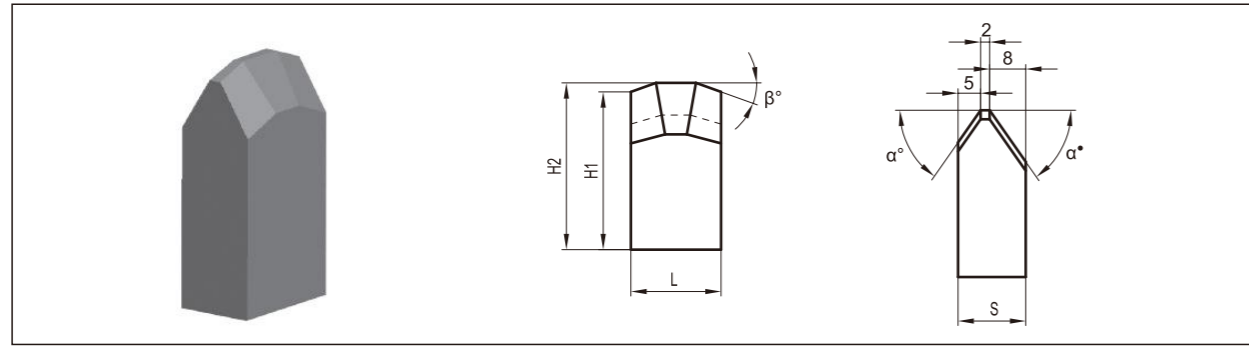

Type	L		H1		H2		S		$\alpha^\circ$	$\beta^\circ$	Approximate unit weight
	Basic dimensions	Allowed tolerance	Basic dimensions	Allowed tolerance	Basic dimensions	Allowed tolerance	Basic dimensions	Allowed tolerance			
LEP097043	20	0 -1	35	+1 0	37	+1 0	15	+0.6 0	55°	19°45'	141.06

Dimensions (mm)

# TUNNEL BORING MACHINE TOOLINGS

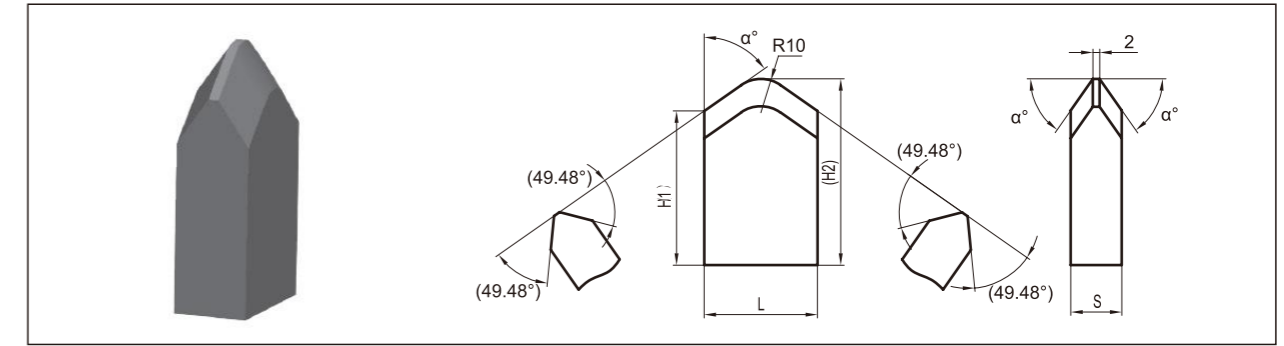

Type	L		H1		H2		S		$\alpha^\circ$	Approximate unit weight
	Basic dimensions	Allowed tolerance	Basic dimensions	Allowed tolerance	Basic dimensions	Allowed tolerance	Basic dimensions	Allowed tolerance		
LEP097056	33.3	0 -1.3	45.3	±0.5	54.58	±0.5	15	+1 0	55°	339.85

Dimensions (mm)

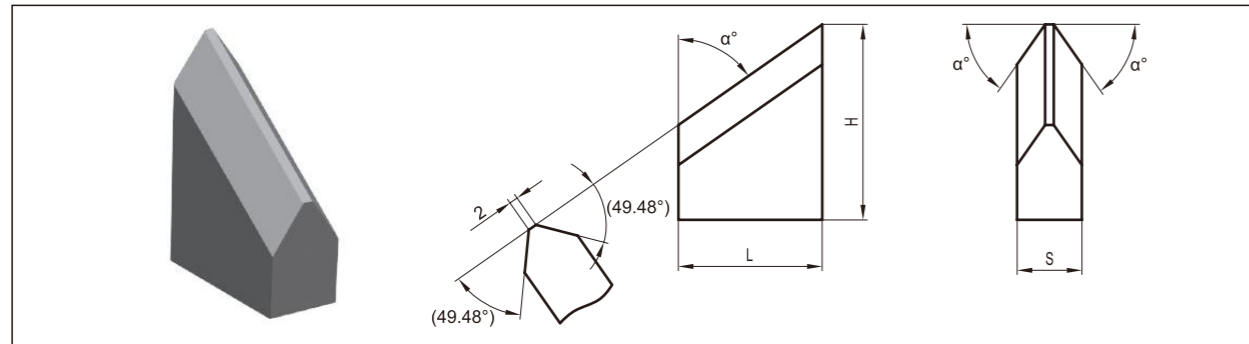

Type	L		H		S		$\beta^\circ$	Approximate unit weight
	Basic dimensions	Allowed tolerance	Basic dimensions	Allowed tolerance	Basic dimensions	Allowed tolerance		
LEP097055	33.3	0 -1	45.3	±0.5	15	+0.6 0	55°	215.29

Dimensions (mm)

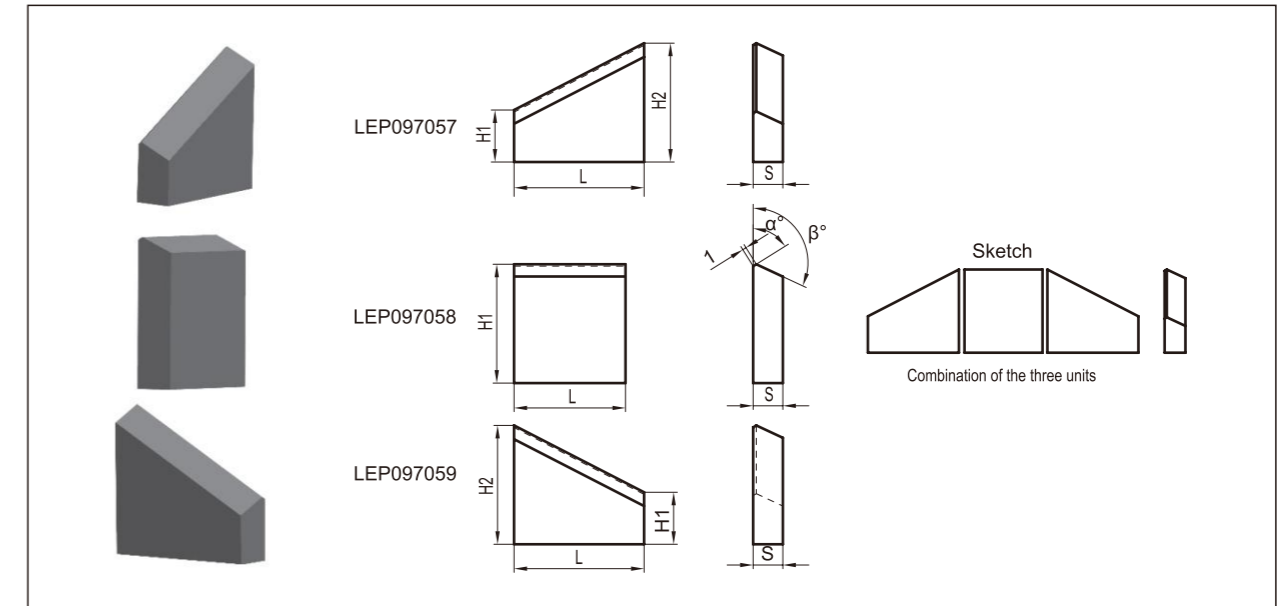

Type	L		H1		H2		S		$\alpha^\circ$	$\beta^\circ$	Approximate unit weight
	Basic dimensions	Allowed tolerance	Basic dimensions	Allowed tolerance	Basic dimensions	Allowed tolerance	Basic dimensions	Allowed tolerance			
LEP097057	35	0 -1.0	14	+1.2 0	32	+1.2 0	8	+0.4 0	58°	115°	96.82
LEP097058	30	0 -1.0	32	+0.8 -0.4			8	+0.4 0			114.63
LEP097059	35	0 -1.0	14	+1.2 0	32	+1.2 0	8	+0.4 0			96.82

Dimensions (mm)



# TUNNEL BORING MACHINE TOOLINGS

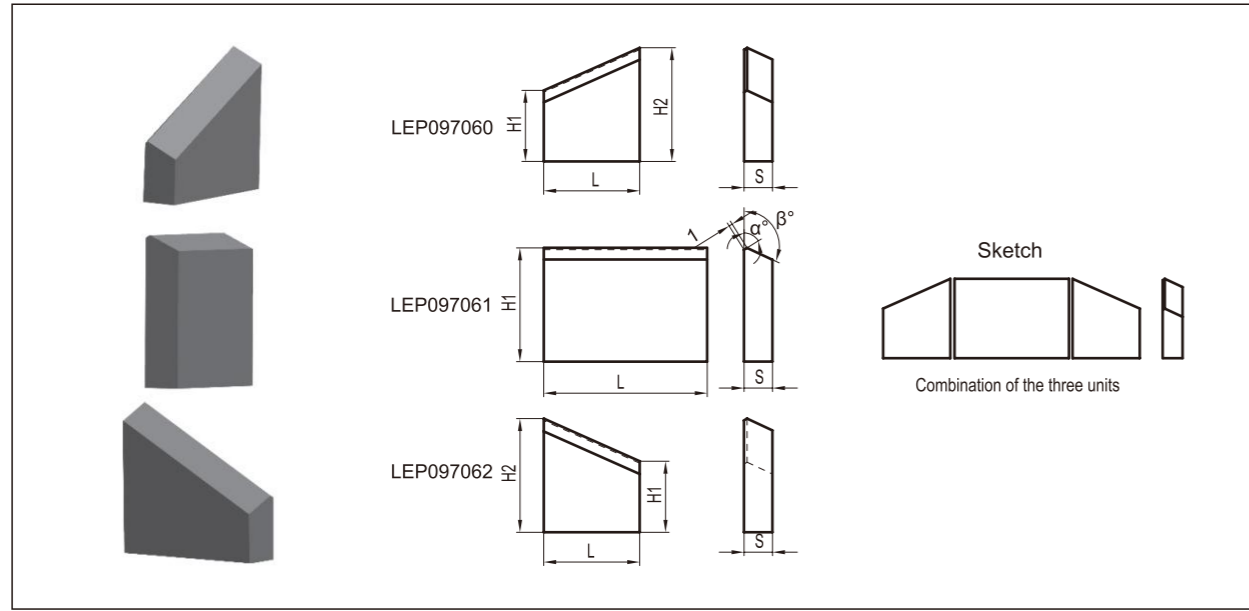

Type	L		H1		H2		S		$\alpha^\circ$	$\beta^\circ$	Approximate unit weight
	Basic dimensions	Allowed tolerance	Basic dimensions	Allowed tolerance	Basic dimensions	Allowed tolerance	Basic dimensions	Allowed tolerance			
LEP097060	27	0 -1.0	20	+0.8 0	32	+0.8 -0.4	8	+0.4 0	58°	115°	83.90
LEP097061	46	0 -1.2	32	+0.8 -0.4			8	+0.4 0			176.42
LEP097062	27	0 -1.0	20	+0.8 0	32	+0.8 -0.4	8	+0.4 0			83.90

Dimensions (mm)

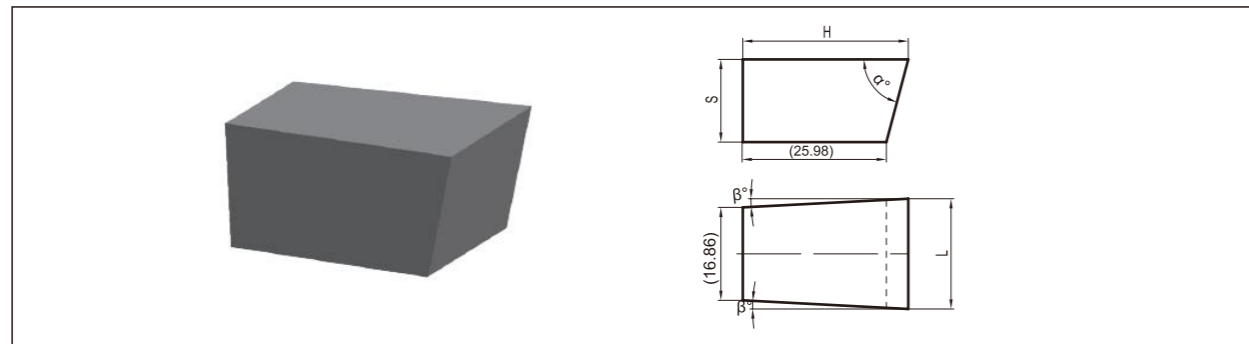

Type	L		H		S		$\alpha^\circ$	$\beta^\circ$	Approximate unit weight
	Basic dimensions	Allowed tolerance	Basic dimensions	Allowed tolerance	Basic dimensions	Allowed tolerance			
LEP107020	20	0 -1	30	+1 0	15	+0.6 0	75°	3°	112.15

Dimensions (mm)

# TUNNEL BORING MACHINE TOOLINGS

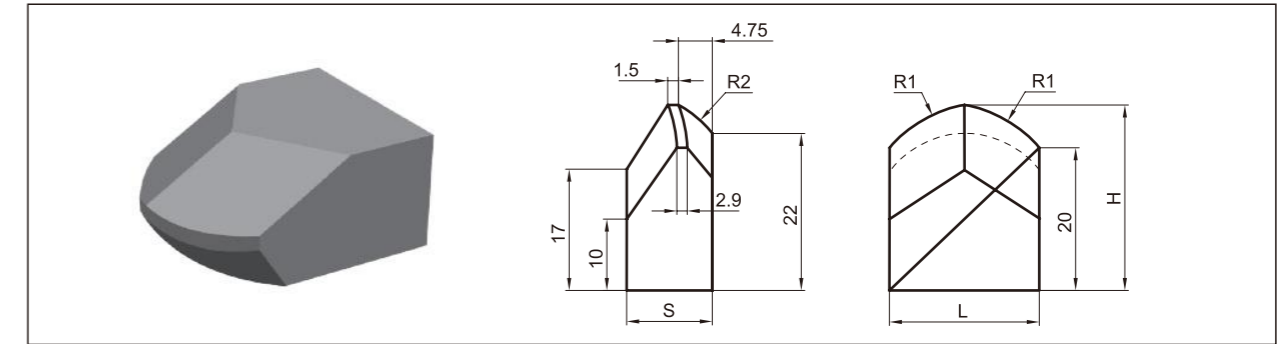

Type	L		H		S		R1	R2	Approximate unit weight
	Basic dimensions	Allowed tolerance	Basic dimensions	Allowed tolerance	Basic dimensions	Allowed tolerance			
LEP128034	21	0 -1	26	+1 0	12	+0.6 0	18	15	75.59

Dimensions (mm)

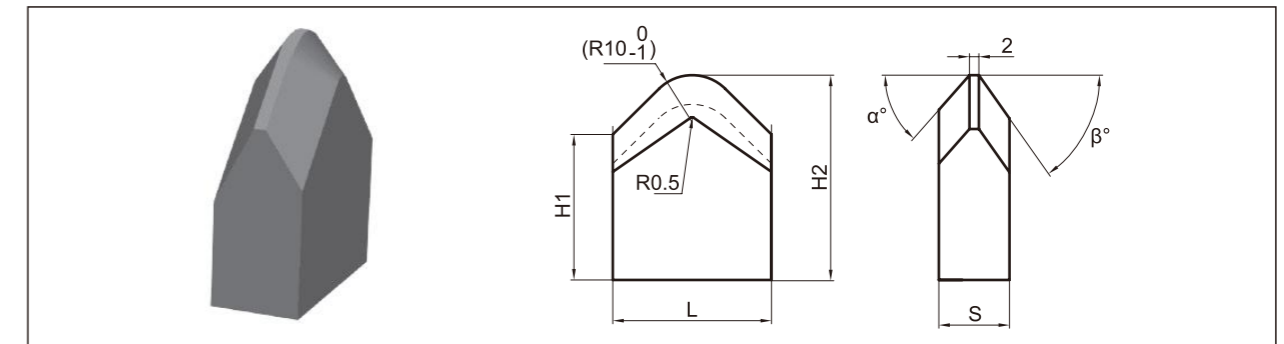

Type	L		H1		H2		S		$\alpha^\circ$	$\beta^\circ$	Approximate unit weight
	Basic dimensions	Allowed tolerance	Basic dimensions	Allowed tolerance	Basic dimensions	Allowed tolerance	Basic dimensions	Allowed tolerance			
LEP128035	33.7	0 -1	30.9	+1 0	43.5	+1 0	15	+0.6 0	47°	55°	252.85

Dimensions (mm)

# TUNNEL BORING MACHINE TOOLINGS

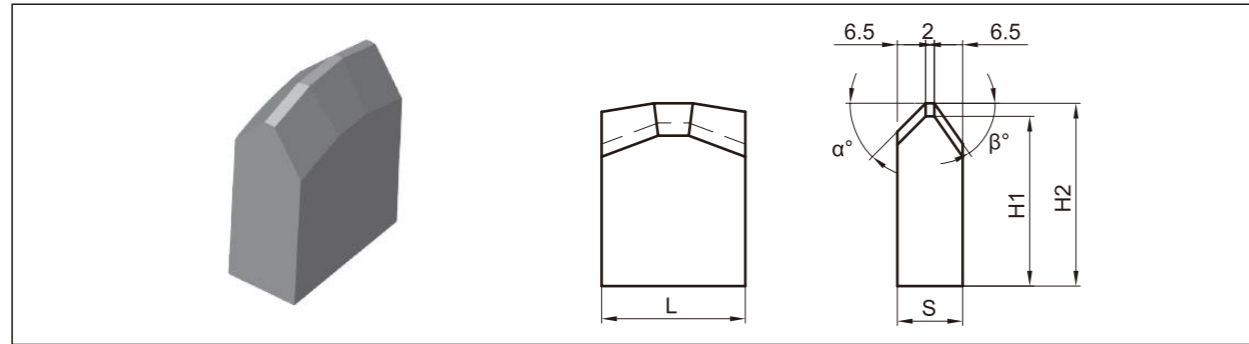

Type	L		H1		H2		S		$\alpha^\circ$	$\beta^\circ$	Approximate unit weight
	Basic dimensions	Allowed tolerance	Basic dimensions	Allowed tolerance	Basic dimensions	Allowed tolerance	Basic dimensions	Allowed tolerance			
LEP128036	33	0 -1	39	+1 0	42	+1 0	15	+0.6 0	45°	55°	272.32

Dimensions (mm)

# TUNNEL BORING MACHINE TOOLINGS

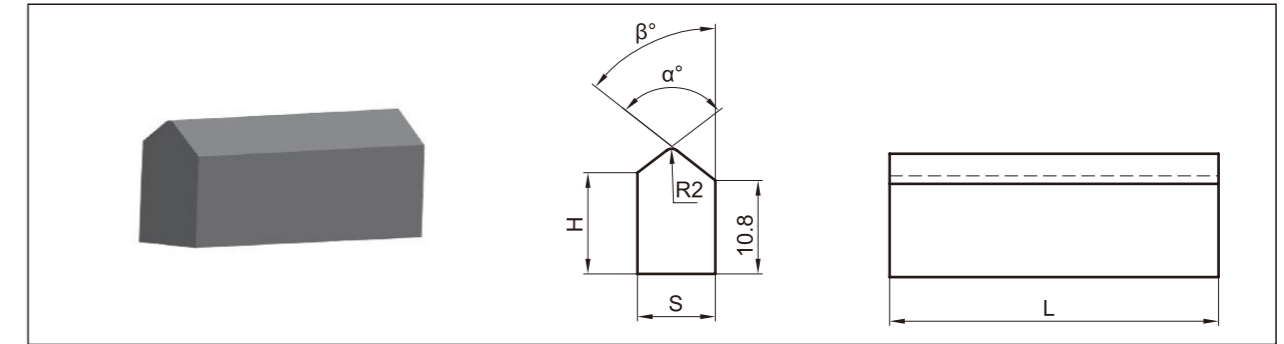

Type	L		H		S		$\alpha^\circ$	$\beta^\circ$	Approximate unit weight
	Basic dimensions	Allowed tolerance	Basic dimensions	Allowed tolerance	Basic dimensions	Allowed tolerance			
LEP128038	38	0 -1	11.7	+0.6 0	9	+0.6 0	105°	52°	66.35

Dimensions (mm)

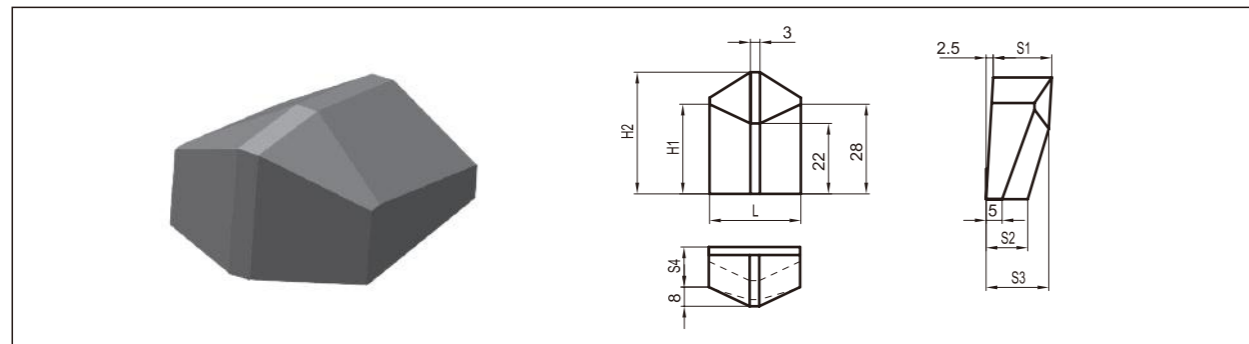

Type	L		H1		H2		S1		S2		S3		S4		Approximate unit weight
	Basic dimensions	Allowed tolerance	Basic dimensions	Allowed tolerance	Basic dimensions	Allowed tolerance	Basic dimensions	Allowed tolerance	Basic dimensions	Allowed tolerance	Basic dimensions	Allowed tolerance	Basic dimensions	Allowed tolerance	
LEP128037	28.5	0 -0.5	30	+1 0	38	+1 0	18	+0.8 0	13	+0.8 0	19	+0.8 0	12.5	+0.8 0	187.65

Dimensions (mm)

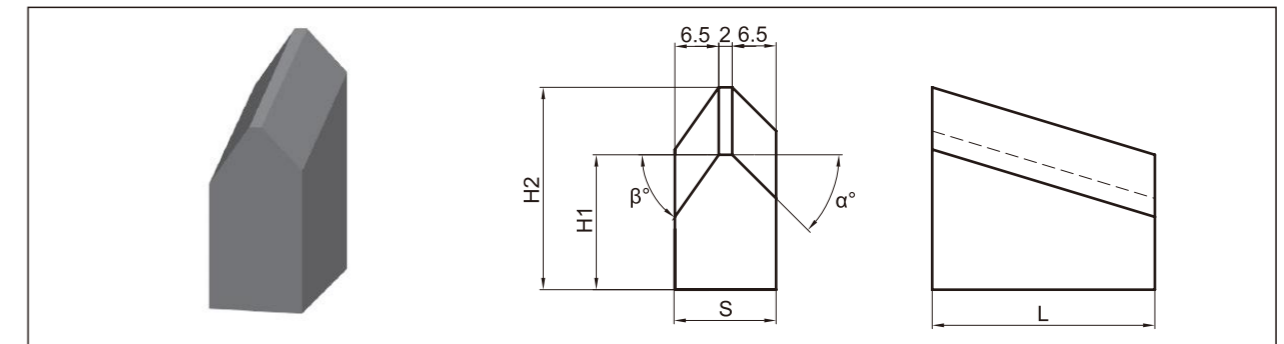

Type	L		H1		H2		S		$\alpha^\circ$	$\beta^\circ$	Approximate unit weight
	Basic dimensions	Allowed tolerance	Basic dimensions	Allowed tolerance	Basic dimensions	Allowed tolerance	Basic dimensions	Allowed tolerance			
LEP128039	33	0 -1	30	+1 0	39	+1 0	15	+0.6 0	45°	55°	236.10

Dimensions (mm)

## TUNNEL BORING MACHINE TOOLINGS

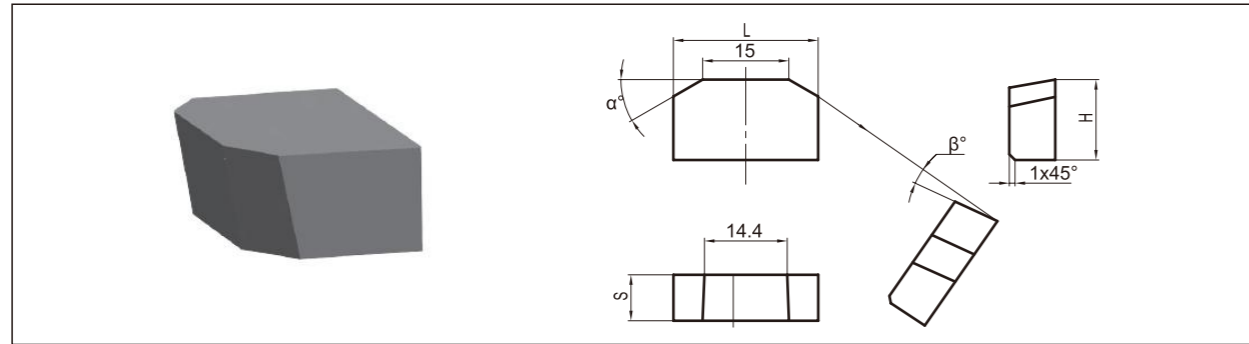

Type	L		H		S		$\alpha^\circ$	$\beta^\circ$	Approximate unit weight
	Basic dimensions	Allowed tolerance	Basic dimensions	Allowed tolerance	Basic dimensions	Allowed tolerance			
ZWP081099	25.2	$\pm 0.3$	14	$\pm 0.3$	8	$\pm 0.2$	30°	10°	35.95

Dimensions (mm)

## TUNNEL BORING MACHINE TOOLINGS

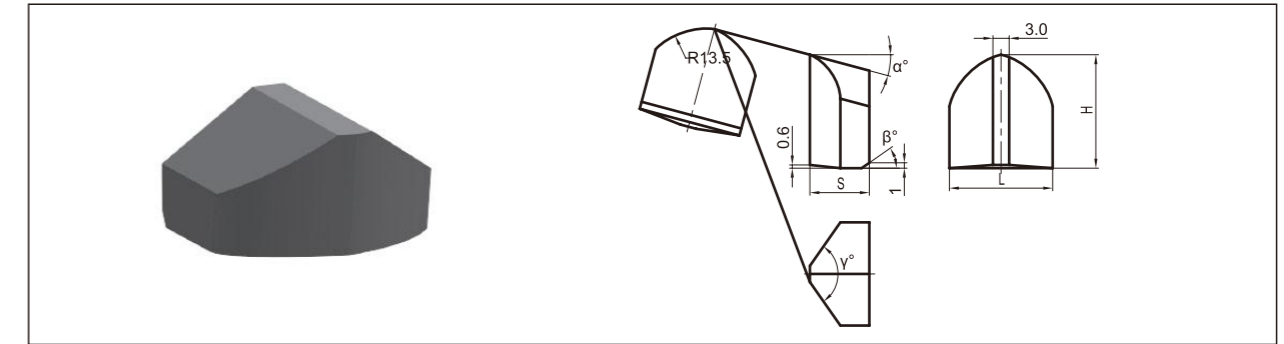

Type	L		H		S		$\alpha^\circ$	$\beta^\circ$	$\gamma^\circ$	Approximate unit weight
	Basic dimensions	Allowed tolerance	Basic dimensions	Allowed tolerance	Basic dimensions	Allowed tolerance				
ZWP081101	19.1	$\pm 0.2$	21.0	$\pm 0.25$	11.0	$\pm 0.2$	15°	35°	110°	40.99

Dimensions (mm)

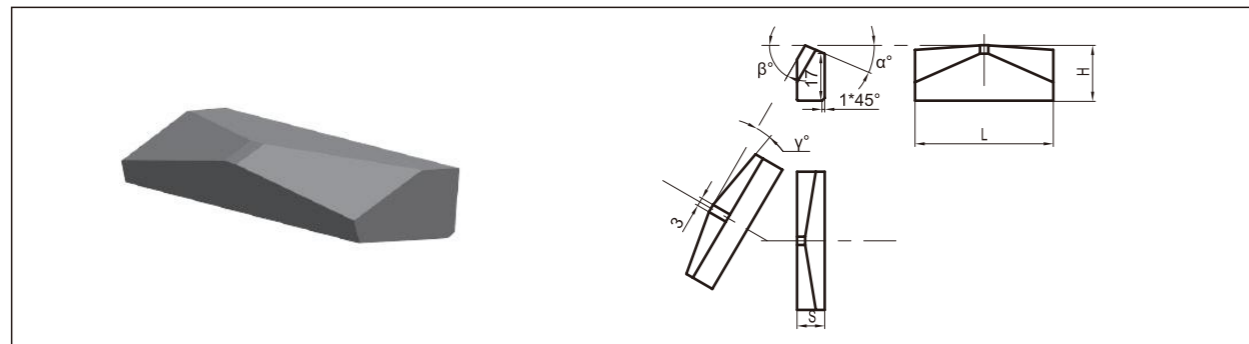

Type	L		H		S		$\alpha^\circ$	$\beta^\circ$	$\gamma^\circ$	Approximate unit weight
	Basic dimensions	Allowed tolerance	Basic dimensions	Allowed tolerance	Basic dimensions	Allowed tolerance				
ZWP081100	50	$\pm 0.3$	20	$\pm 0.15$	10	$\pm 0.15$	23°	60°	10°	120.40

Dimensions (mm)

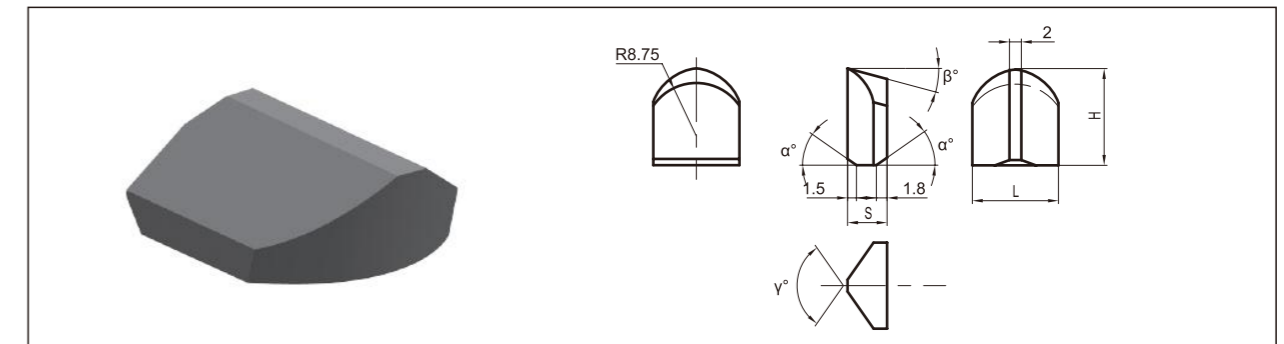

Type	L		H		S		$\alpha^\circ$	$\beta^\circ$	$\gamma^\circ$	Approximate unit weight
	Basic dimensions	Allowed tolerance	Basic dimensions	Allowed tolerance	Basic dimensions	Allowed tolerance				
ZWP097296	14.5	$\pm 0.20$	16.3	$\pm 0.25$	6.65	$\pm 0.20$	35°	15°	110°	14.10

Dimensions (mm)





# SOCIAL RESPONSIBILITY

Focusing on the new development landscape featuring carbon peaking, carbon neutrality, and dual circulation, China Minmetals actively expands new standards, new technology, green energy, and digital intelligence, and continuously promotes intelligent, efficient, green and low-carbon development. It creates a more optimized lifestyle, and contributes to China's high-quality and sustainable development.

ZCC Group has been once again recognized as an environmental credit and integrity enterprise in Hunan Province. In accordance with people-orientated management philosophy, ZCC empowers the staff, provides quality service for customers and makes contributions to building a harmonious society. ZCC is dedicated to the development of staff, enterprise and society.

Aimed at becoming an environmental-friendly enterprise, ZCC implemented clean production and promoted environmental protection by eliminating its energy-intensive production lines and introducing new technologies, new processes and new energy resources. In May 2011, the natural gas boiler system went into operation, and the last two chimneys were removed.

# WORLDWIDE SALES NETWORK



ZCC adopts international business strategy. Sales branches in Germany, the US, etc. were successively set up. Products of ZCC are exported to more than 70 countries and regions around the world. Adhering to the brand position of "first in China, first-class in the world", ZCC has become a reliable business partner of world-renowned enterprises, such as Schlumberger and Kennametal, through business cooperation and technology development. ZCC constantly strengthens itself by shaping brand, and fully integrates international resources including brand, technology, channels, and culture.

Looking ahead, ZCC is committed to the rejuvenation of China's tungsten industry. Bearing in mind the spirit of "pursuing excellence with relentless efforts", ZCC will create a cemented carbide group that is "first in China, first-class in the world" by constantly improving its technological innovation capacity and playing a leading role in the industry.

## U.S.A

**Zhuzhou Cemented Carbide Works USA Inc.**  
4651 Platt Lane Ann Arbor, MI 48108, USA.

TEL: +1-734-302-0125  
FAX: +1-734-302-0126  
EMAIL: [info@zccamerica.com](mailto:info@zccamerica.com)

## Europe

**ZCC Europe GmbH**

## HK,China

**Zhuzhou Cemented Carbide Group HongKong Co.,Ltd.**