



**ZCC America**

# ZCC America

HEADQUARTERS:  
ZHUSHOU CEMENTED CARBIDE GROUP CO., LTD.  
ZHUSHOU CEMENTED CARBIDE WORKS IMP. & EXP. CO.

**Zhuzhou Cemented Carbide Works USA Inc.**

4651 Platt Lane Ann Arbor, MI 48108, USA.

TEL: +1-734-302-0125

FAX: +1-734-302-0126

EMAIL: [info@zccamerica.com](mailto:info@zccamerica.com)

[WWW.ZCCAMERICA.COM](http://WWW.ZCCAMERICA.COM)

2024 VERSION

## CARBIDES FOR METAL FORMING

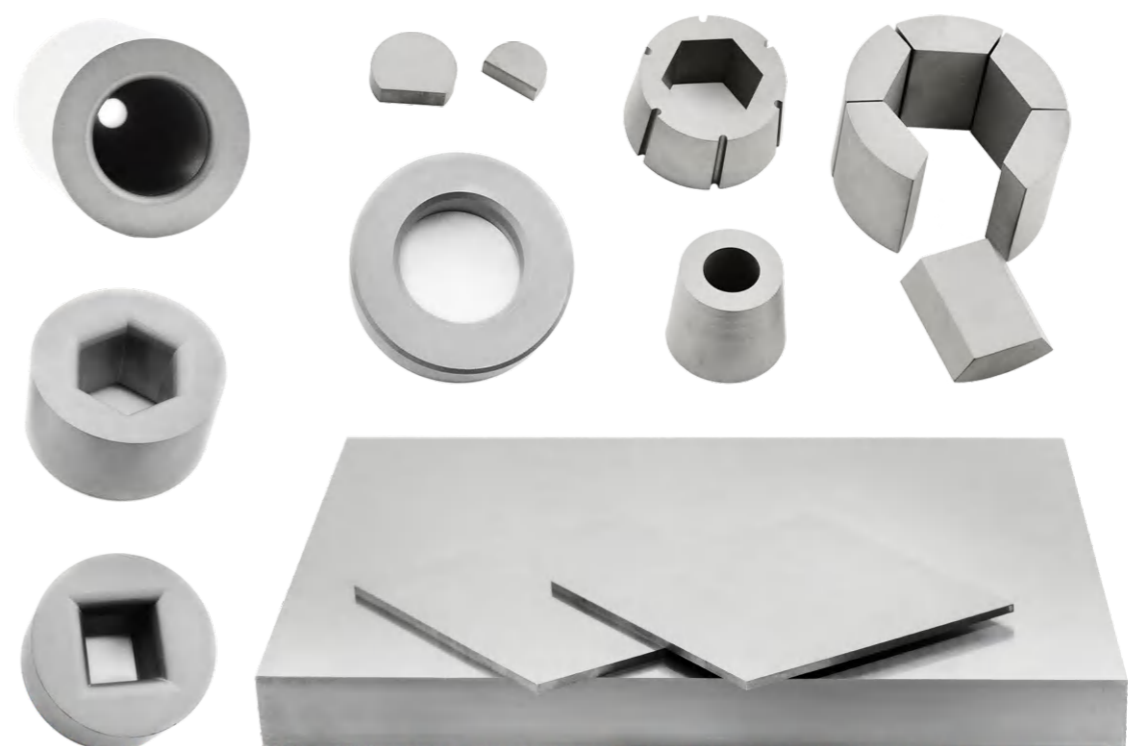

# CONTENTS



ABOUT ZCC	01
PRODUCTION CAPACITY	03
R&D	05
QUALITY ASSURANCE	09
WEAR PARTS DIVISION	11

<b>CEMENTED CARBIDE DRAWING DIE NIBS</b>	15
<b>CEMENTED CARBIDE COLD HEADING DIE BLANKS</b>	39
<b>CEMENTED CARBIDE BLOCKS FOR MOULD MAKING</b>	52



# ABOUT ZCC



Zhuzhou Cemented Carbide Group Co., LTD (ZCC), hailed as "the cradle of China's cemented carbide industry", is one of the 156 key projects constructed during the First Five-Year Plan. ZCC is a key enterprise of China Minmetals Corporation, one of the Fortune Global 500 companies. ZCC specializes in cemented carbides, which are known as "the teeth of industry" and are widely applied to military industry, aerospace, mechanical processing, metallurgy, petroleum drilling, mining tools, electronic communication, construction, among other fields.

ZCC is a leading enterprise in the cemented carbide industry with the largest production and sales scale in China. It is also a "world-class professional leading demonstration enterprise" awarded by China's State-owned Assets Supervision and Administration Commission of the State Council (SASAC). It is also a national manufacturing champion demonstration enterprise, a national technological innovation demonstration enterprise, a high-tech enterprise, and a national green factory. On March 21, 2023, Chinese Premier Li Qiang, also a member of the Standing Committee of the Political Bureau of the Communist Party of China Central Committee, fully approved ZCC's work in sci-tech innovation and product development during his visit.

## 1954

### FOUNDATION

One of the 156 major projects that China constructed in 1954 during the First Five-Year Plan

## 1958

### THE FIRST CEMENTED CARBIDE DRAWING DIE

China's first piece of cemented carbide drawing die was born in ZCC

## 1984

### NATIONAL HIGH-QUALITY PRODUCT AWARD

ZCC's cold heading die of grade YG20C was awarded National High-Quality Product

## 2007

### A SERIES OF NEW GRADES

MZ series carbide plates with excellent corrosion resistance and better machined surface were released

## 2017

### WEAR PARTS DIVISION

Wear Parts Division was integrated in order to provide professional service for customers

# PRODUCTION CAPACITY

Under ZCC, there are 8 professional production units: Profile Products Branch, Big Products Division, Drill Business Division, Special Products Division, Drilling and Tunneling Division, Powder Division, RTP Plant, and Mold Manufacturing Plant; as well as 4 wholly owned and holding subsidiaries: ZCC Cutting Tools Co., Ltd. (ZCC.CT), Jinzhou Cemented Carbide Co., Ltd. (Jinzhou), Zhuzhou Changjiang Carbide Tools Co., Ltd., and ZCC Works Imp.& Exp.Co., Ltd.

Among them, ZCC.CT is a leading enterprise in domestic cemented carbide cutting tools, and has been rated as high-tech enterprise of Hunan Province, key high-tech enterprise under the National Torch Plan, innovative enterprise of Hunan Province, and national innovative enterprise. Jinzhou is a global leading player of micro cutting tools, and a manufacturing champion demonstration enterprise.

**8** PROFESSIONAL PRODUCT DIVISIONS

**3** R&D CENTERS

**1** ANALYSIS AND TESTING CENTER

**4** HOLDING SUBSIDIARIES

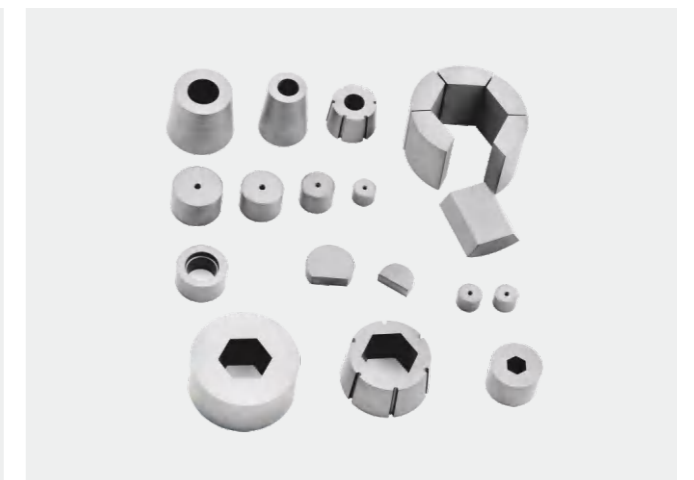



# R&D



ZCC is in possession of the only national key laboratory of cemented carbide industry, one of the first batch of certified state-level enterprise technology centers, state-level analysis and testing center, and quality-control and technology-evaluation laboratory of industrial products (cemented carbides and other tungsten products). ZCC undertakes many of the the national "863" and "973" programs, national innovation capacity building programs, the national key technology R&D program, and national strategic innovative products and key new products project. The company has won the first and second prizes of national sci-tech progress, and the second prize of national invention.





Products of ZCC have been widely applied to the forefront of "Made in China 2025" and "the Belt and Road Initiative". Some typical achievements have solved the bottleneck problems of national industrial development. High-end cemented carbide products can be produced domestically, thus holistically promoting related industries.

The production technology of spiral tools for deep-hole drilling has led to the emergence of independent high-end cemented carbide processing tools in China's automotive industry. The development of cemented carbide roller rings for low-temperature rolling has enabled domestic rollers to be the preferred choice of steel enterprises. The industrial application enables PDC cemented carbide matrix to be a key material for energy extraction in deep/ultra deep wells with a depth of more than 3000 meters. Thanks to the production of ultra-fine diameter cemented carbides for micro drilling and milling, China's PCB processing is taking the lead globally.



# QUALITY ASSURANCE

ZCC always adheres to the quality policy of "laying emphasis on technology, being strict with management, and placing quality on top priority to meet customers' requirements with the Diamond brand". ZCC has acquired certificate of QHSE management system (quality, health and safety, and environment). ZCC has been adhering to the concept of "all for the customers" by respecting customers' requirements, and constantly improving technical and market services.





# WEAR PARTS DIVISION



Wear Parts Division was integrated in 2017, with more than 240 professional employees and an annual output of more than 1,000 tons.

Wear Parts Division produces a wide range of products with multiple applications. With the ability to intensively process various types of products, it specializes in cemented carbide plates, cold heading die blanks, drawing dies, shield cutters, rolling cutters, long strips, cast nails, all kinds of special non-standard wear-resistant parts and steel-bonded carbide products, which are widely used in punching, building materials, mining, petrochemical, iron and steel, hardware, textiles, among other industries.

Adhering to customer-oriented principle, Wear Parts Division constantly improves its service and delivery by closely focusing on customers' needs, enhancing technical support, and providing customized production of non-standard products.







# CEMENTED CARBIDE DRAWING DIE NIBS

# GRADE PROPERTIES

Grade series	Grade	ISO grade	Co	Density	Hardness		TRS	Grain size
			wt%	g/cm <sup>3</sup>	HRA	HV30	Sample B, MPa	μm
MU series	MU10	K01-K05	6	14.73	94.5	2110	2100	Ultrafine
	MU15	K05-K10	6.5	14.70	94.3	2080	1750	
	MU35	K05-K10	8	14.48	94.3	2080	2000	
MF series	MF20	K05-K10	6	14.90	93.3	1850	2860	Submicron
	MF25	K05-K10	6	14.93	92.5	1710	2600	
	MF40	K10-K20	8	14.63	92.6	1720	3400	
	MF50	K20-K40	10	14.45	91.5	1580	3400	
MA series	MA20	K10	6	14.92	92.4	1700	2400	Fine/Medium
	MA25	K20	6	14.95	91.3	1540	2900	
	MA30	K20	6	14.94	90.4	1440	2800	
	MA40	K30	8	14.76	89.9	1390	3100	

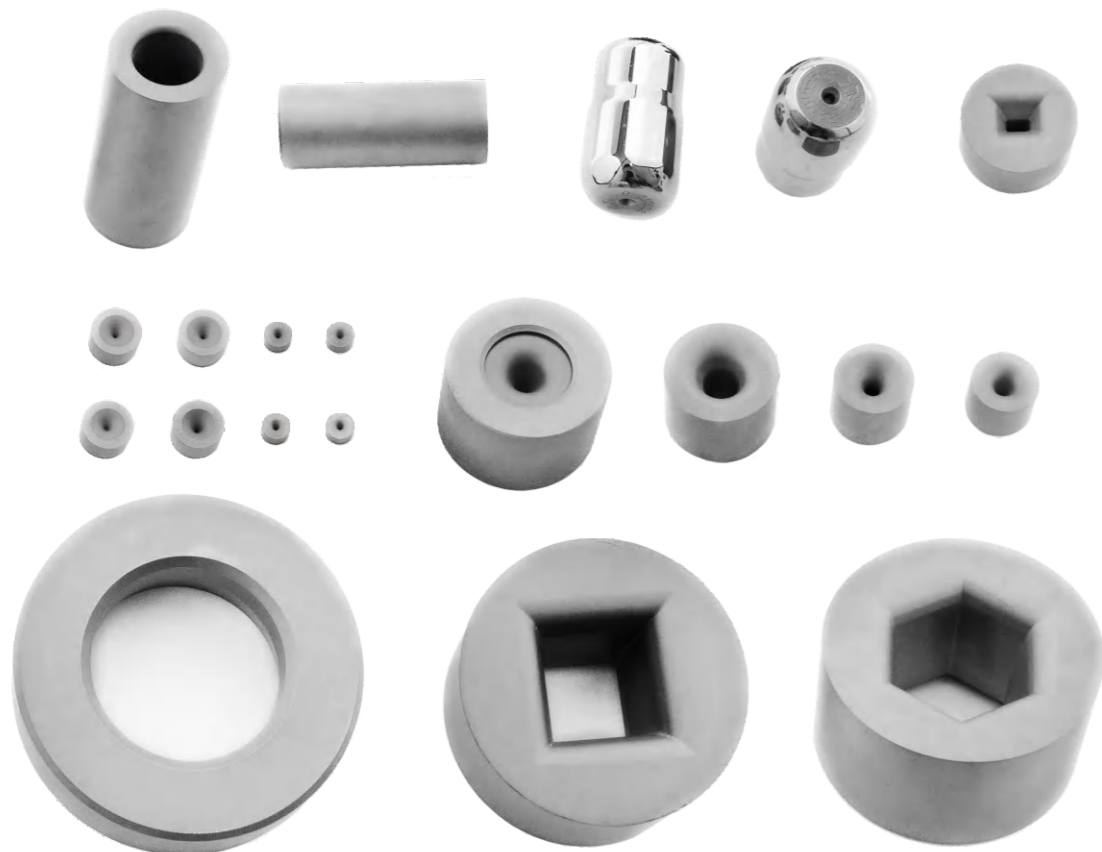

Relationship HV30 and Co content (MU, MF and MA series)

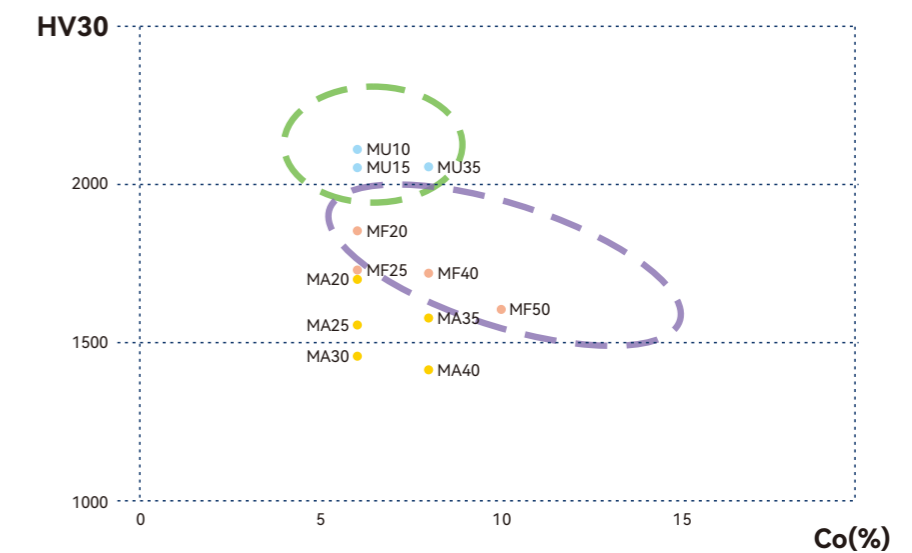



## NEW GRADE

New grade	Grain size / $\mu\text{m}$	Application
MU35	0.2	Suitable for wet drawing of high carbon steel wire, steel cord wire, cutting wire, coated wire and welding wire.
MF25	0.8	Suitable for high carbon steel, welding wire wet/dry drawing, non-ferrous metal dry drawing, CVD matrix.

## Microstructure chart

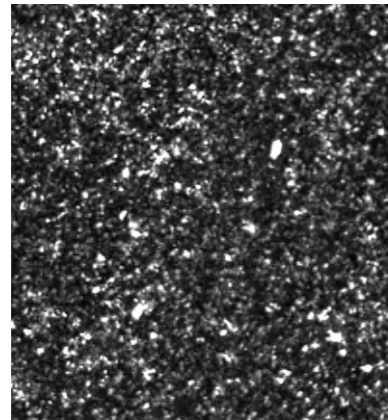

MU35

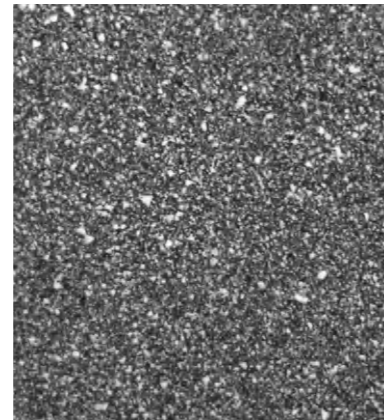

MF25

## Classification and representation of drawing dies

Drawing dies are divided into 15 categories according to die type and material of the processed workpiece.

S11 metal wire drawing die	22 metal pipe drawing die
S13 metal wire drawing die	23 metal pipe drawing die
A metal wire and rods drawing die	30 cores for metal pipe drawing die
V metal wire drawing die	31 cores for metal pipe drawing die
W metal wire and rods drawing die	40 Square Metal Rods Drawing Die
GS2 metal wire drawing die	42 metal strip drawing die
10 metal wire drawing die	60 hexagonal metal rods drawing die
13 nonferrous metal wire drawing die	

## Type representation of drawing dies

Type of drawing dies consists of 5 codes: type classification, outer diameter, height, compression angle, and inner hole parameter.

example	S11-008		06	12-1.2	
	1	2	3	4	5

- 1 See classification and representation of drawing dies.
- 2 Outer diameter code consists of 3 digits (unit: mm). If there is less than 3 digits, add "0" in the front.
- 3 Height code consists of 2 digits (unit: mm). If there is less than 2 digits, add "0" in the front.  
Compression angle code consists of 2 digits (unit: °). If there is no compression angle, the code is "00".
- 4 Inner hole code.
- 5 The circular inner hole is represented by "d", inner diameter dimension (unit: mm). When "d" is no more than 1 mm, round to 2 decimal places; when "d" is more than 1 mm, round to 1 decimal place.  
Quadrilateral inner hole is represented by "hole length × hole width" (unit: mm), rounded to 1 decimal place.  
Hexagonal inner hole is represented by "s", incircle dimension (unit: mm), rounded to 1 decimal place.



# PRODUCT TYPES

## TYPE S11

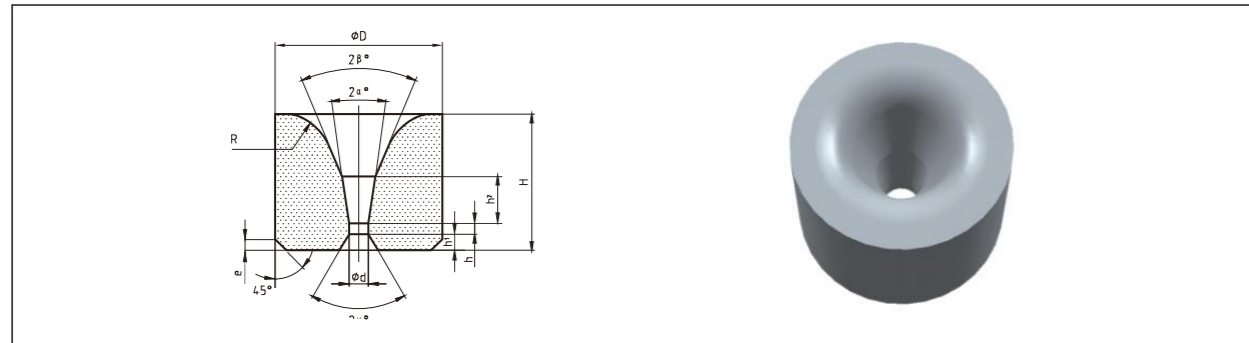

Type	D×H	2α	d
S11-0080610-d	8×6	10°	0.6, 0.8, 0.9, 1.0
S11-0080612-d	8×6	12°	0.2, 0.25, 0.3, 0.35, 0.4, 0.45, 0.6, 0.8, 0.9, 1.0
S11-0080616-d	8×6	16°	0.4, 0.5, 0.6, 0.7, 0.8
S11-0131010-d	13×10	10°	0.4, 0.5, 0.6, 0.7, 0.8, 0.9, 1.0, 1.1, 1.2, 1.3, 1.4, 1.5, 1.6, 1.7, 1.8, 2.0, 2.2, 2.3, 2.5
S11-0131014-d	13×10	14°	0.35, 0.4, 0.5, 0.6, 0.7, 0.8, 0.9, 1.0
S11-0131016-d	13×10	16°	1.1, 1.2, 1.3, 1.4, 1.5, 1.6, 1.7, 1.8, 1.9, 2.0, 2.1, 2.2, 2.3, 2.4, 2.5, 2.6
S11-0161310-d	16×13	10°	0.4, 0.6, 0.7, 0.8, 0.9, 1.0
S11-0161312-d	16×13	12°	1.1, 1.2, 1.3, 1.4, 1.5, 1.6, 1.7, 1.8, 1.9, 2.0, 2.1, 2.2, 2.3, 2.4, 2.5, 2.6, 2.7, 2.8, 3.0, 3.2, 3.5
S11-0161316-d	16×13	16°	0.3, 0.4, 0.5, 0.6, 0.8, 0.9, 1.0, 1.1, 1.2, 1.3, 1.4, 1.5, 1.6, 1.7, 1.8, 1.9, 2.0, 2.1, 2.2, 2.3, 2.4, 2.5, 2.6, 2.7, 2.8, 3.0, 3.3
S11-0201718-d	20×17	18°	1.6, 1.8, 1.9, 2.0, 2.1, 2.2, 2.3, 2.5, 2.6, 2.8, 3.0, 3.3, 3.5, 3.8, 4.0, 4.2, 4.5, 4.7, 4.9, 5.2, 5.7, 5.9
S11-0221814-d	22×18	14°	1.7, 1.8, 2.0, 2.1, 2.3, 2.4, 2.5, 2.6, 2.8, 3.1, 3.3, 3.5, 3.7, 3.8, 4.0, 4.2, 4.5, 4.7, 5.0
S11-0221818-d	22×18	18°	1.3, 1.5, 1.6, 1.7, 1.8, 1.9, 2.0, 2.2, 2.3, 2.4, 2.5, 2.6, 2.7, 2.8, 2.9, 3.0, 3.1, 3.3, 3.5, 3.6, 3.8, 4.0, 4.2, 4.4, 4.5, 4.7, 4.9, 5.0, 5.2, 5.4, 5.5, 5.6, 5.7, 6.0
S11-0222014-d	22×20	14°	5.2, 5.5, 5.7

mm

# PRODUCT TYPES

## TYPE S13

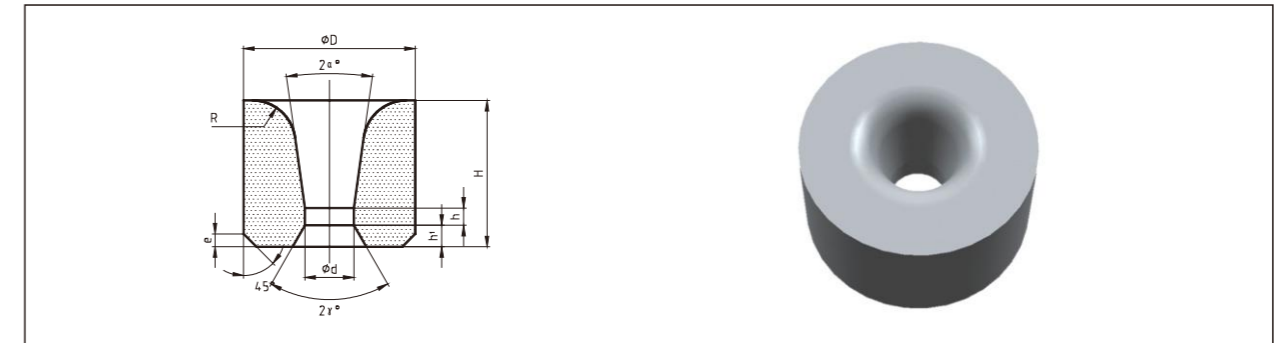

Type	D×H	2α	d
S13-0201716-d	20×17	16°	1.8, 2.0, 2.3, 2.8, 3.3, 3.8, 4.2, 4.7, 5.2, 5.5, 5.7
S13-0281820-d	28×18	20°	5.7, 6.0, 6.3, 6.6, 7.0, 7.3, 7.7, 8.2, 8.6
S13-0282014-d	28×20	14°	3.7, 5.5, 5.7, 6.0, 6.3, 6.6, 6.7, 7.0, 7.5, 7.7
S13-0282020-d	28×20	20°	4.7, 5.0, 5.2, 5.4, 5.7, 6.0, 6.2, 6.5, 6.7, 7.0, 7.3, 7.5, 7.7, 8.2, 8.6, 9.0, 9.1, 9.3, 9.6
S13-0302114-d	30×21	14°	3.7, 4.1, 4.6, 4.7, 5.0, 5.3, 5.7, 6.0, 6.3, 6.7, 7.0, 7.5, 7.7, 8.0, 8.6, 9.6
S13-0302119-d	30×21	19°	3.7, 4.1, 4.7, 5.0, 5.3, 5.4, 5.5, 5.7, 6.0, 6.5, 6.7, 7.0, 7.2, 7.3, 7.7, 8.1, 8.6, 9.0, 9.6
S13-0352420-d	35×24	20°	9.6, 10.1, 10.5, 11.5
S13-0382420-d	38×24	20°	10.5, 11.5, 12.5, 13.5, 14.5
S13-0402508-d	40×25	8°	8.0, 8.5, 9.0, 10.0, 10.5
S13-0402516-d	40×25	16°	10.5, 11.5, 12.5, 13.5, 14.5
S13-0402519-d	40×25	19°	10.5, 11.5, 12.5, 13.5, 14.5
S13-0502816-d	50×28	16°	16.5, 17.5, 18.5, 19.5, 20.5, 21.5, 22.5, 23.5, 24.5
S13-0502819-d	50×28	19°	16.5, 17.5, 18.5, 19.5, 20.5, 21.5, 22.5, 23.5, 24.5
S13-0603519-d	60×35	19°	25.5, 26.5, 27.5, 28.5, 29.5, 30.5, 31.5, 32.5, 33.5, 34.5
S13-0653519-d	65×35	19°	32.5, 33.5
S13-0753518-d	75×35	18°	41.5
S13-0753520-d	75×35	20°	34.5, 35.5, 36.5, 37.5, 38.5, 39.5, 40.5
S13-0803520-d	80×35	20°	41.5, 42.5, 43.5
S13-0903520-d	90×35	20°	45.0, 46.0, 47.0, 49.0, 51.0, 53.0, 55.0
S13-1104020-d	110×40	20°	61.5, 64.0, 67.0, 69.0
S13-1405020-d	140×50	20°	74.0

mm



# PRODUCT TYPES

## TYPE A

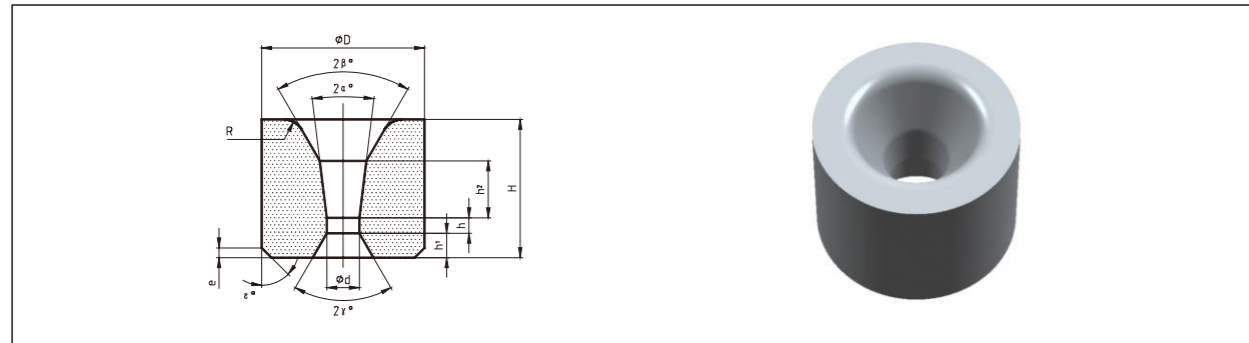

Type	D×H	2α	d
A-0100812-d	10×8	12°	0.15, 0.2, 0.25, 0.3, 0.4, 0.5, 0.6, 0.7, 0.8, 0.9, 1.0
A-0121012-d	12×10	12°	0.4, 0.5, 0.6, 0.7, 0.8, 0.9, 1.0, 1.1, 1.2, 1.3, 1.4, 1.5, 1.6, 1.7, 1.8
A-0141212-d	14×12	12°	0.8, 1.0, 1.8, 2.0
A-0161312-d	16×13	12°	0.6, 0.7, 0.8, 0.9, 1.0, 1.1, 1.2, 1.3, 1.4, 1.5, 1.6, 1.7, 1.8, 1.9, 2.0, 2.1
A-0161314-d	16×13	14°	2.2, 2.4, 2.6, 2.7, 2.8, 2.9, 3.0
A-0201712-d	20×17	12°	1.0, 1.1, 1.2, 1.3, 1.4, 1.5, 1.6, 1.7
A-0201714-d	20×17	14°	1.8, 1.9, 2.0, 2.1, 2.2, 2.3, 2.4, 2.5, 2.6, 2.7, 2.8, 2.9, 3.0, 3.2, 3.3, 3.5, 3.7, 3.8, 4.0, 4.2, 4.5, 4.7, 4.8
A-0252014-d	25×20	14°	3.0
A-0252016-d	25×20	16°	4.7, 5.2, 5.5, 5.7, 6.0, 6.2
A-0252118-d	25×21	18°	6.5, 7.0, 7.5, 8.0, 8.5
A-0302416-d	30×24	16°	3.0, 3.8, 4.2, 4.7, 5.2, 5.7, 6.2, 7.3, 7.7, 8.2, 8.7, 9.0, 9.5, 9.7

mm

# PRODUCT TYPES

## TYPE V

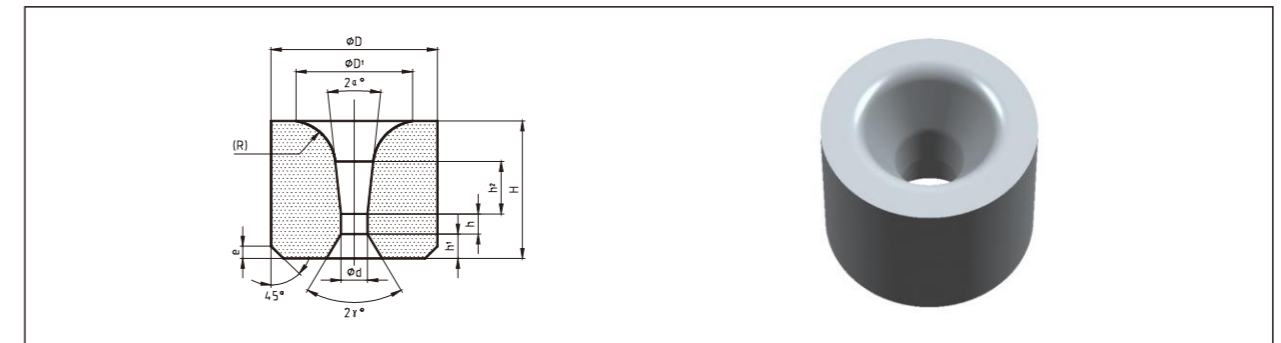

Type	D×H	2α	d
V-0151312-d	15×13	12°	0.6, 0.7, 0.8, 0.9, 1.0, 1.1, 1.2, 1.3, 1.4, 1.5, 1.6, 1.7, 1.8, 1.9, 2.0, 2.1, 2.3, 2.5, 2.6, 2.7, 2.8, 3.0, 3.3, 3.6
V-0151316-d	15×13	16°	1.0, 1.2, 1.3, 1.6, 1.8, 2.0, 2.2, 2.3, 2.5, 2.6, 2.8, 3.0, 3.3, 3.5, 3.6
V-0191712-d	19×17	12°	1.8, 1.9, 2.0, 2.1, 2.2, 2.3, 2.4, 2.5, 2.6, 2.8, 2.9, 3.0, 3.2, 3.3, 3.5, 3.6, 3.8, 3.9, 4.1, 4.2, 4.5, 4.6, 4.9, 5.2, 5.5, 5.6, 5.9, 6.2
V-0252014-d	25×20	14°	5.7, 6.0, 6.2, 6.5, 6.7, 7.0, 7.2, 7.7
V-0302114-d	30×21	14°	8.2, 8.6, 9.0, 9.3, 9.6, 10.0, 10.5, 11.0, 11.5

mm



# PRODUCT TYPES

## TYPE W

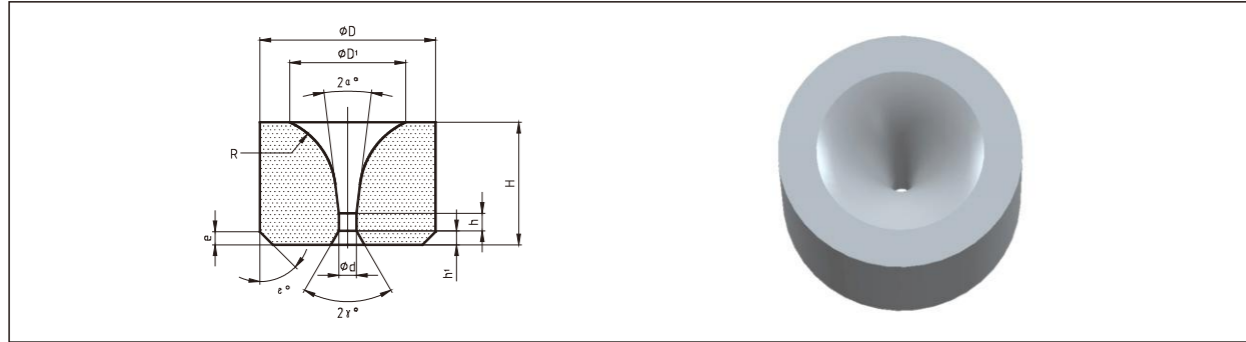

Type	D×H	2α	d
W-0060412-d	6×4	12°	0.2, 0.3
W-0080612-d	8×6	12°	0.2, 0.25, 0.3, 0.4, 0.5
W-0090612-d	9×6	12°	0.12, 0.15, 0.16, 0.18, 0.2, 0.22, 0.25, 0.3, 0.35, 0.4, 0.45, 0.5, 0.55, 0.6, 0.7, 0.8
W-0120812-d	12×8	12°	0.9, 1.2
W-0120814-d	12×8	14°	0.2, 0.3, 0.4, 0.5, 0.6, 0.7, 0.8, 0.9, 1.0, 1.1, 1.2, 1.3, 1.4, 1.5, 1.6, 1.7, 1.8, 2.2, 2.3, 2.4, 2.5, 2.7, 2.8
W-0151014-d	15×10	14°	0.7, 0.8, 0.9, 1.0, 1.1, 1.2, 1.3, 1.4, 1.5, 1.6, 1.7, 1.8, 1.9, 2.0, 2.1, 2.2, 2.3, 2.4, 2.5, 2.6, 2.7, 2.8, 2.9, 3.0, 3.1, 3.2, 3.3, 3.4, 3.5, 3.6, 3.7, 3.8, 3.9, 4.0, 4.1, 4.2, 4.3, 4.4, 4.5, 4.6, 4.7, 4.8, 4.9, 5.0, 5.1, 5.2, 5.3, 5.4
W-0201414-d	20×14	14°	1.0, 1.1, 1.2, 1.3, 1.4, 1.5, 1.6, 1.7, 1.8, 1.9, 2.0, 2.1, 2.2, 2.3, 2.4, 2.5, 2.6, 2.7, 2.8, 2.9, 3.0, 3.1, 3.2, 3.3, 3.4, 3.5, 3.6, 3.7, 3.8, 3.9, 4.0, 4.1, 4.2, 4.3
W-0201416-d	20×14	16°	4.4, 4.5, 4.6, 4.7, 4.8, 4.9, 5.0, 5.1, 5.2, 5.3, 5.4, 5.5, 5.6, 5.7, 5.8, 5.9, 6.2, 6.8, 7.0, 7.1, 7.2, 7.8
W-0251814-d	25×18	14°	3.0, 3.4, 3.6, 3.8, 4.0, 4.2, 4.4, 4.5, 4.8, 5.1, 5.3, 5.5, 5.8, 6.0, 6.3, 7.0
W-0251816-d	25×18	16°	5.8, 6.3, 6.4, 6.5, 6.8, 7.1, 7.3, 7.7, 7.8, 8.3, 8.8
W-0302216-d	30×22	16°	5.8, 6.0, 6.8, 7.2, 7.7, 8.0, 8.4, 9.0, 9.4, 10.0, 10.5, 11.0

mm

# PRODUCT TYPES

## TYPE GS2

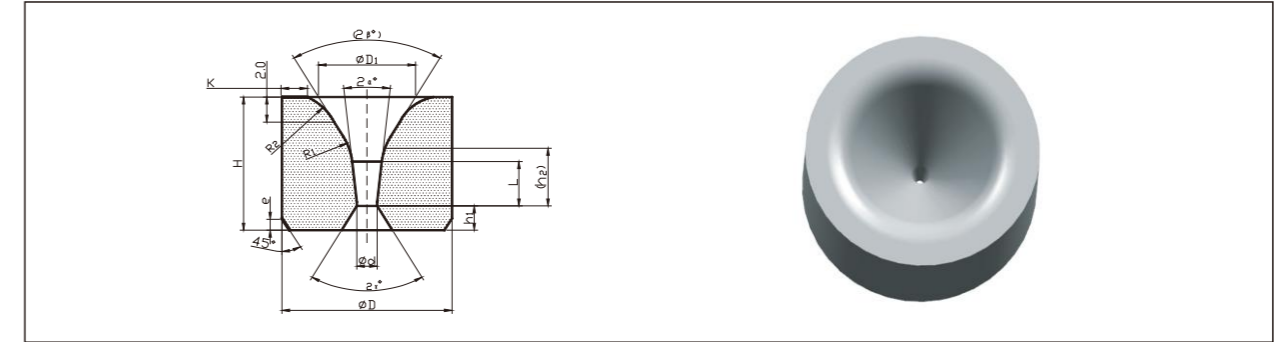

Type	D×H	2α	d
GS2-0161312-d	16×13	12°	0.6, 0.8, 1.0, 1.2, 1.4, 1.6, 1.8, 2.0, 2.2
GS2-0201712-d	20×17	12°	1.3, 1.6, 1.8, 2.0, 2.2, 2.4, 2.6, 2.7, 2.9, 3.2, 3.5, 3.8, 4.1, 4.8

mm



# PRODUCT TYPES

## TYPE 10 / TYPE 12

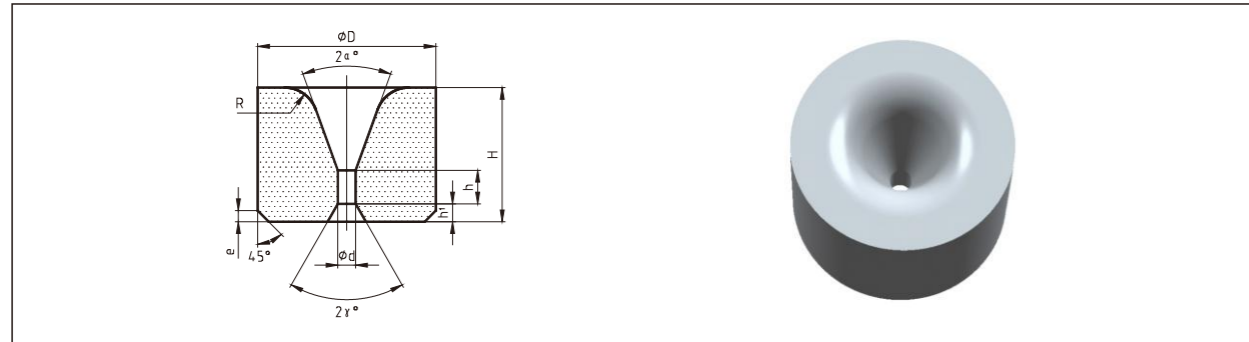

Type	D×H	2α	d
10-0060440-d	6×4	40°	0.4, 0.6, 0.8
10-0080640-d	8×6		0.4, 0.6, 0.8

mm

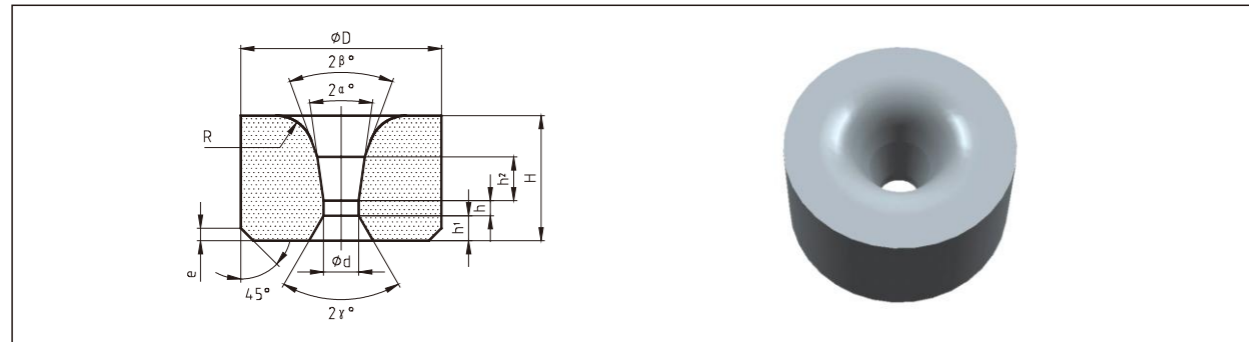

Type	D×H	2α	d
12-0130816-d	13×8	16°	0.4, 0.5, 0.6, 0.7, 0.8, 0.9, 1.0, 1.1, 1.2, 1.3, 1.4, 1.5, 1.6, 1.7, 1.8, 1.9, 2.0, 2.1, 2.2, 2.3
12-0161016-d	16×10	16°	0.8, 0.9, 1.0, 1.1, 1.2, 1.3, 1.4, 1.5, 1.6, 1.7, 1.8, 1.9, 2.0, 2.1, 2.2, 2.3, 2.4, 2.5, 2.6, 2.7, 2.8
12-0201216-d	20×12	16°	1.8, 1.9, 2.0, 2.1, 2.2, 2.3, 2.4, 2.5, 2.6, 2.7, 2.8, 2.9, 3.1, 3.3, 3.5, 3.8, 4.0, 4.3, 4.6, 5.0
12-0221416-d	22×14	16°	4.2, 4.5, 4.7, 5.0, 5.2, 5.5, 5.7
12-0261616-d	26×16	16°	6.4, 6.7, 7.0, 7.2, 7.5, 7.7, 8.0

mm

# PRODUCT TYPES

## TYPE 22

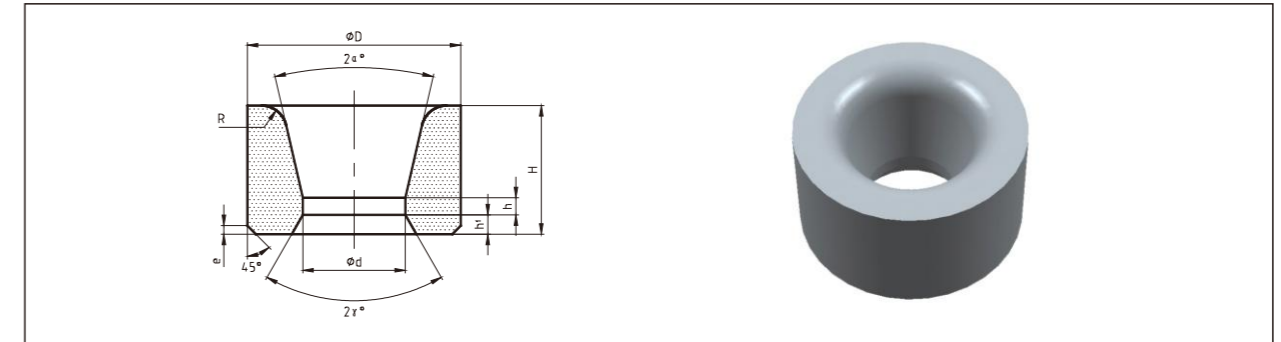

Type	D×H	2α	d
22-0201324-d	20×13	24°	2.8, 2.9, 3.0, 3.2, 3.4, 3.6, 3.8, 4.0, 4.3, 4.6, 4.7, 5.0, 5.3, 5.6, 5.7
22-0251624-d	25×16	24°	7.2
22-0201326-d	20×13	26°	6.5, 7.0, 7.5, 8.0, 8.5, 9.0, 10.2
22-0301824-d	30×18	24°	6.7, 7.0, 7.3, 7.6, 8.1, 8.6, 9.1, 9.6, 10.1, 10.5, 11.5, 13.5
22-0352224-d	35×22	24°	15.5
22-0452424-d	45×24	24°	12.5, 13.5, 14.5, 15.5, 16.5, 17.5, 18.5, 19.5, 20.5, 21.5, 22.5, 23.5
22-0603024-d	60×30	24°	24.5, 25.5, 26.5, 27.5, 28.5, 29.5, 30.5, 31.5
22-0803524-d	80×35	24°	34.5, 35.5, 36.5, 37.5, 38.5, 39.5, 40.0, 41.5, 42.0, 43.5, 44.5, 46.5, 47.0
22-0904024-d	90×40	24°	49.0, 50.0, 51.0, 52.0, 53.0, 54.0
22-1204524-d	120×45	24°	59.0, 60.0, 61.0, 62.0, 63.0, 64.0, 65.0, 66.0, 67.0
22-1405024-d	140×50	24°	79.0, 80.0, 81.0, 82.0, 83.0, 84.0, 85.0, 86.0, 87.0, 88.0

mm



# PRODUCT TYPES

## TYPE 23

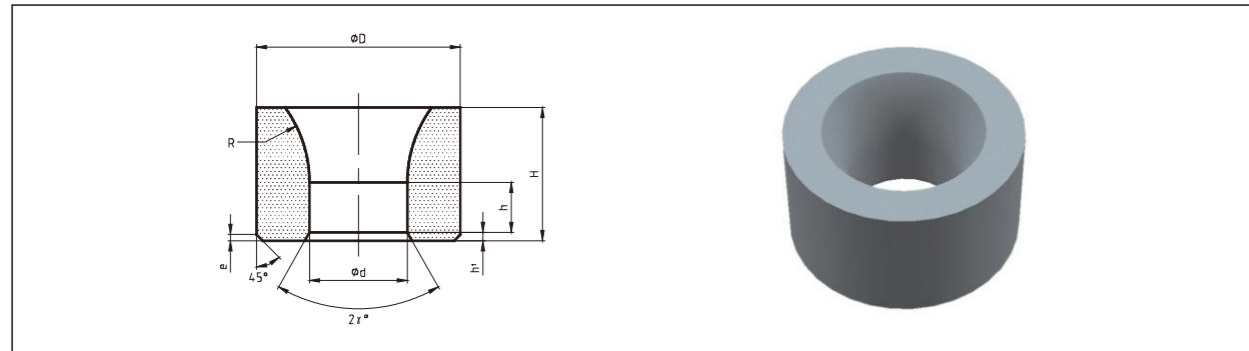

Type	D×H	2α	d
23-0301800-d	30×18	0°	11.7
23-0503200-d	50×32	0°	20.0, 22.0, 24.0
23-0603500-d	60×35	0°	26.0, 28.0, 30.0
23-0704200-d	70×42	0°	32.0, 34.0, 36.0
23-0754200-d	75×42	0°	38.0, 42.0
23-0854500-d	85×45	0°	42.0, 46.0, 48.0
23-1005000-d	100×50	0°	48.0, 50.0, 52.0, 54.0
23-1105000-d	110×50	0°	56.0, 58.0, 60.0, 62.0
23-1255500-d	125×55	0°	64.0, 66.0, 68.0, 70.0

mm

# PRODUCT TYPES

## TYPE 30

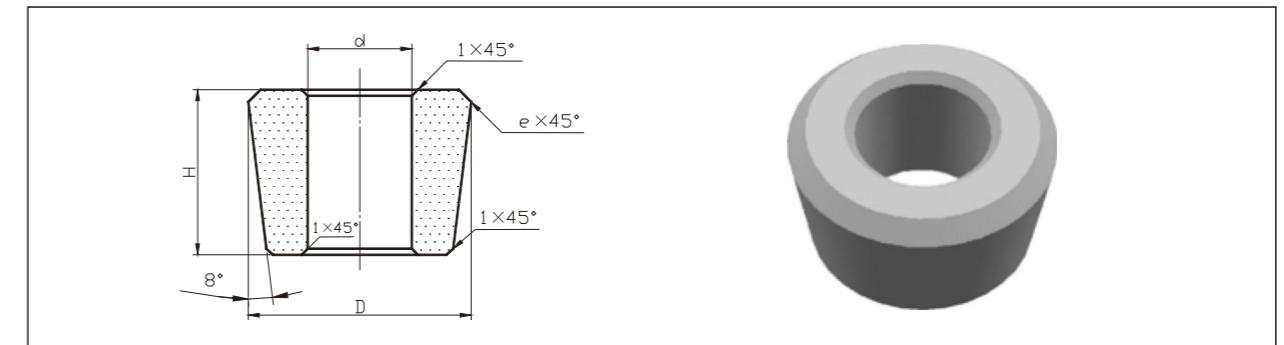

Type	D	H	d	e
30-0151200-6.0	15	12	6	1
30-0171200-8.0	17	12	8	1
30-0191400-10.0	19.5	14	10	1
30-0211400-10.0	21.5	14	10	1
30-0231600-12.0	23.5	16	12	1
30-0251600-14.0	25.5	16	14	1
30-0271600-14.0	27.5	16	14	2
30-0282700-15.0	28	27	15	2
30-0292700-15.0	29.2	27	15	2
30-0302700-15.0	30.4	27	15	2
30-0312700-15.0	31.6	27	15	2
30-0322700-15.0	32.2	27	15	2
30-0332700-15.0	33.4	27	15	2
30-0342700-17.0	34	27	17	2
30-0352700-17.0	35.2	27	17	2
30-0362700-17.0	36.4	27	17	2
30-0372700-19.0	37	27	19	2
30-0382700-19.0	38.2	27	19	2
30-0392700-19.0	39.4	27	19	2
30-0603500-28.0	60	35	28	4

mm



# PRODUCT TYPES

## TYPE 31

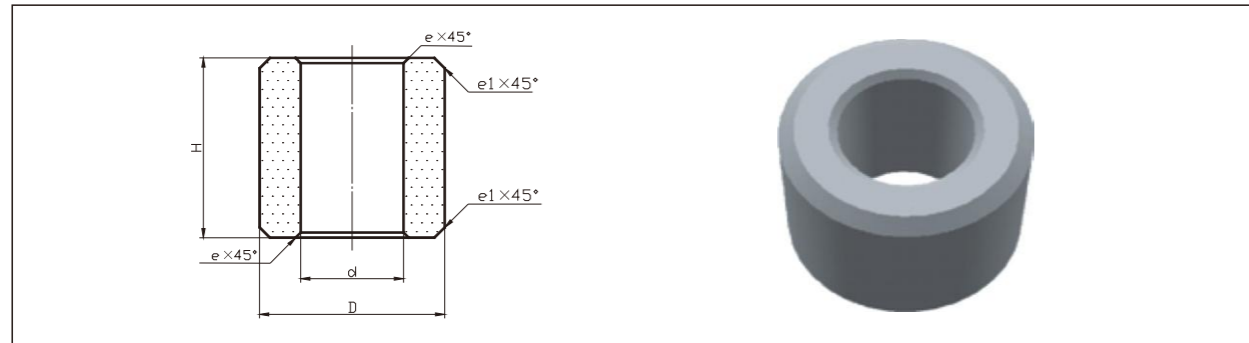

Type	D	H	d	e1	e
31-0142500-7.0	14	25	7	1	0.5
31-0152500-7.0	15	25	7	1	0.5
31-0162500-7.0	16	25	7	1	0.5
31-0172500-8.0	17	25	8	1	0.5
31-0182500-8.0	18	25	8	1	0.5
31-0193000-10.0	19	30	10	1	0.5
31-0203000-10.0	20	30	10	1	0.5
31-0213000-10.0	21	30	10	1	0.5
31-0223000-10.0	22	30	10	1	0.5
31-0233000-12.0	23	30	12	1	0.5
31-0243000-12.0	24	30	12	1	0.5
31-0253000-12.0	25	30	12	1	0.5
31-0263000-12.0	26	30	12	1	0.5
31-0273000-12.0	27	30	12	1	0.5
31-0283500-16.0	28	35	16	1	0.5
31-0293500-16.0	29	35	16	1	0.5
31-0303500-16.0	30	35	16	1	0.5
31-0313500-16.0	31	35	16	2	0.5
31-0323500-16.0	32	35	16	2	0.5
31-0333500-20.0	33	35	20	2	0.5
31-0343500-20.0	34	35	20	2	0.5
31-0353500-20.0	35	35	20	2	0.5

mm

# PRODUCT TYPES

## TYPE 31

Type	D	H	d	e1	e
31-0363500-20.0	36	35	20	2	0.5
31-0373500-20.0	37	35	20	2	0.5
31-0383500-20.0	38	35	20	2	0.5
31-0393500-20.0	39	35	20	2	0.5
31-0403500-20.0	40	35	20	2	0.5
31-0413500-20.0	41	35	20	2	1
31-0423500-20.0	42	35	20	2	1
31-0434000-22.0	43	40	22	2	1
31-0444000-22.0	44	40	22	2	1
31-0454500-26.4	45	45	26.4	2	1
31-0464500-26.4	46	45	26.4	2	1
31-0474500-26.4	47	45	26.4	2	1

mm



# SPECIAL TYPES AND CUSTOMIZED

## TYPE 40 SQUARE METAL RODS DRAWING DIE

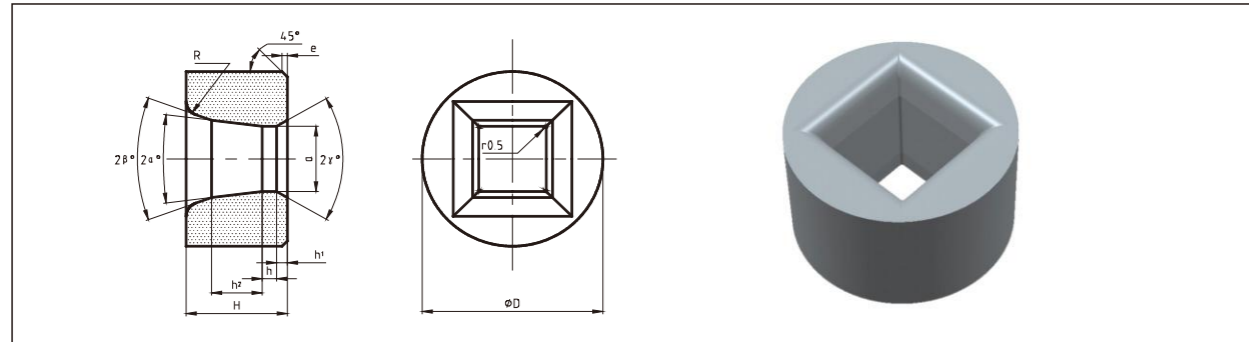

Type	D×H	2α	Hole length a × Hole width b
40-0221814-d	22×18	14°	4.0
40-0302114-d	30×21	14°	4.6、5.7
40-0603016-d	60×30	16°	19.7、21.7

mm

# SPECIAL TYPES AND CUSTOMIZED

## TYPE 42 METAL STRIP DRAWING DIE

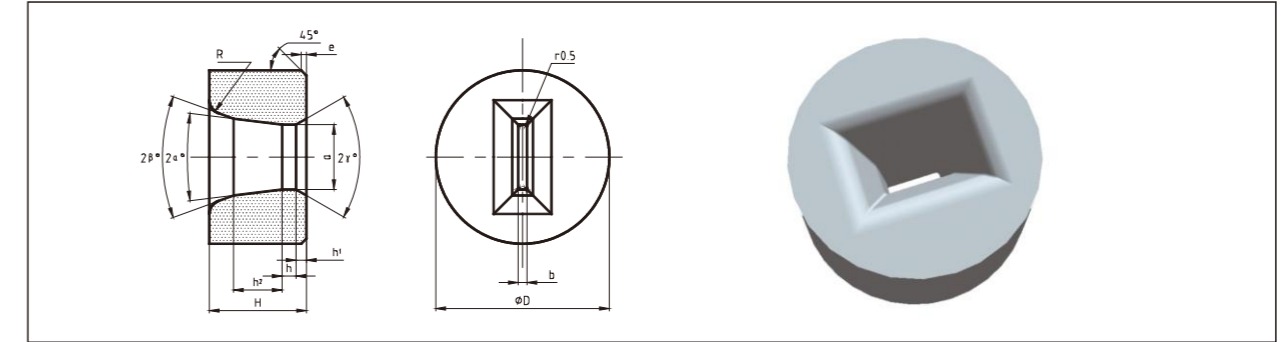

Type	D×H	2α	Hole length a × Hole width b
42-0201218-a×b	20×12	18°	1.9×1.0、1.9×1.4、2.4×1.0、2.4×1.4、3.1×1.0、3.1×1.4、3.1×1.9
42-0221218-a×b	22×12	18°	3.0×0.6、4.0×0.6、5.0×1.1
42-0251518-a×b	25×15	18°	3.9×1.0、3.9×1.5、3.9×1.9、3.9×2.4、4.5×1.1、4.5×1.5、4.5×1.9、4.5×2.4、4.5×2.8、5.3×1.1、5.3×1.5、5.3×1.9、5.3×2.3、6.2×1.1、6.2×1.5、6.2×1.9
42-0351818-a×b	35×18	18°	6.2×3.1、7.2×1.1、7.2×1.5、7.2×1.9、7.2×2.4、7.2×3.1、8.4×1.2、8.4×1.5、8.4×2.4、9.1×3.8、9.8×1.2、10.8×1.9
42-0452018-a×b	45×20	18°	12.8×1.4
42-0502018-a×b	50×20	18°	17.6×1.5

mm

# SPECIAL TYPES AND CUSTOMIZED

## TYPE 60 HEXAGONAL METAL RODS DRAWING DIE

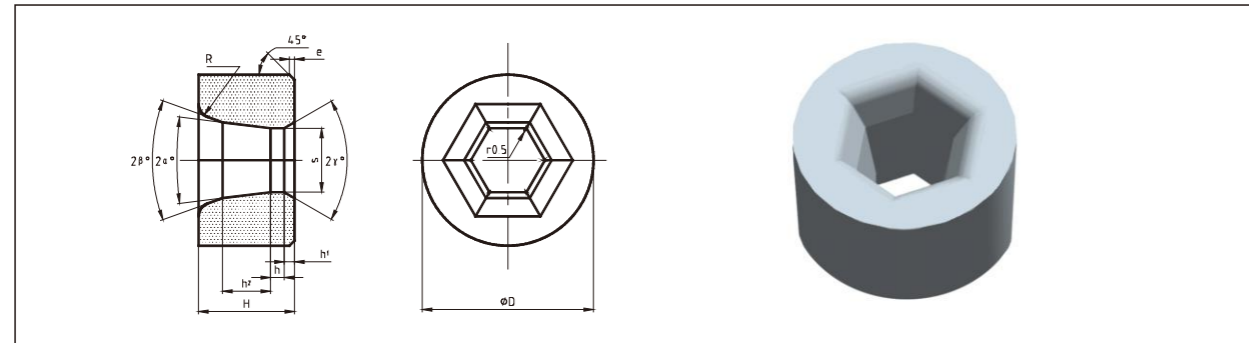

Type	D×H	2α	Hole length a × Hole width b
60-0302114-s	30×21	14°	3.0、4.0、4.7、5.7、6.7、7.7
60-0352114-s	35×21	14°	8.6、9.6、10.6
60-0352122-s	35×21	22°	9.6、10.6
60-0402514-s	40×25	14°	11.5、12.5
60-0452514-s	45×25	14°	13.5、18.5
60-0552814-s	55×28	14°	23.5

mm

# DIMENSION STANDARD

## WITH CIRCULAR HOLES

### Inner Diameter

Basic dimensions	Tolerance	Basic dimensions	Tolerance
0.1~0.3	0 -0.05	>9~24	0 -0.30
>0.3~0.4	0 -0.06	>24~32	0 -0.50
>0.4~0.6	0 -0.08	>32~40	0 -0.60
>0.6~3	0 -0.10	>40~55	0 -0.80
>3~6	0 0.15	>55~90	0 -1.00
>6~9	0 -0.20	-	-

mm

### Outer Diameter

Basic dimensions	Tolerance	Basic dimensions	Tolerance
≤10	+0.20 0	>35~40	±0.30
>10~16	+0.30 0	>40~45	±0.35
>16~30	+0.40 0	>45~50	±0.40
>30~35	±0.25	>50	±1.0%D

mm

### Height Dimension

Basic dimensions	Tolerance	Basic dimensions	Tolerance
≤10	±0.2	>30~40	±0.5
>10~20	±0.3	>40~50	±0.5
>20~30	±0.4	>50~60	±0.8

mm



# DIMENSION STANDARD

TYPE 30 AND TYPE 31 CORE HEAD

## Inner Diameter

Basic dimensions	Tolerance
≤20	+0.8
	0
> 20~30	+1.0
	0

mm

## Outer Diameter

Basic dimensions	Tolerance
>10~20	+0.6
	+0.2
>20~30	+0.7
	+0.2
>30~40	+0.8
	+0.2
>40~50	+0.9
	+0.2
>50~60	+1.0
	+0.2
>60	+1.2
	+0.2

mm

## Height Dimension

Basic dimensions	Tolerance
>10~20	±0.45
>20~30	±0.50
>30~40	±0.55
>40~50	±0.60

# DIMENSION STANDARD

WITH POLYGONAL HOLES

## Inner Diameter

Basic dimensions	Tolerance	Basic dimensions	Tolerance
≤2	0	> 20~25	0
	-0.25		-0.85
> 2~4	0	> 25~32	0
	-0.35		-0.90
> 4~6	0	> 32~40	0
	-0.40		-1.00
> 6~12	0	> 40~50	0
	-0.50		-1.40
> 12~16	0	> 50~60	0
	-0.65		-1.80
> 16~20	0	> 60~75	0
	-0.75		-2.00

mm

## Outer Diameter

Basic dimensions	Tolerance	Basic dimensions	Tolerance
≥7~30	±0.5	> 65~80	+1.8
			-1.3
> 30~50	±0.8	> 80~120	+2.3
			-1.8
> 50~65	±1.3	-	-

mm

## Height Dimension

Basic dimensions	Tolerance	Basic dimensions	Tolerance
≤20	±0.4	>40~50	±0.8
> 20~30	±0.5	>50~60	±1.0
> 30~40	±0.6	-	-

mm

## THE ROLE OF EACH PART OF THE CARBIDE DRAWING DIE

### 1. Inlet zone

The transition from the inlet zone to the working zone follows a circular trajectory to facilitate the entry of the drawing material into the working zone while preventing the material from being abraded by the edges of the die hole.

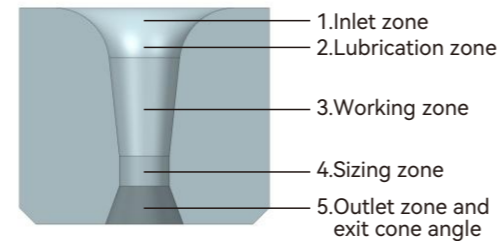

### 2. Lubrication zone

Its function is to store lubricant to lubricate the drawing material and facilitate the working process.

### 3. Working zone

It is the zone of plastic deformation in which the metal is drawn. The choice of this zone is mainly determined by length and cone angle. If the length is too small, the stretched metal will impose too much pressure on the working zone. The tensile stress will then increase significantly, leading to faster wear of the die. The length of the working zone varies with the metal's material, diameter and lubrication requirement. Choice of length follows the following principles:

- 1) The length for drawing hard metal wire should be shorter than that for drawing soft ones.
- 2) The length for drawing small-diameter wires should be shorter than that for large-diameter wires.
- 3) Strength for mixed lubrication should be shorter than that for dry lubrication.

Cone angle: the angle for drawing steel is relatively small, while that for drawing non-ferrous metals and their alloys is relatively large.

### 4. Sizing zone

The size of the drawing products are confirmed in the sizing zone. The length of the sizing zone varies depending on material hardness, size of the cross-sectional area and lubrication requirements. If the sizing zone is too large, there will be friction and temperature increase, thus reducing the service life of the die. In addition, tensile stress will also increase, resulting in higher wire breakage rate and power consumption. If the sizing zone is too short, the size of the drawn product will be affected when the working cone changes during drawing. Generally, the sizing zone for soft metal material is shorter than that for hard metal material. The sizing zone for large-diameter material is shorter than that for small-diameter material, and that for wet drawing is shorter than that for dry drawing.

### 5. Outlet zone and exit cone angle

The drawn material passes the outlet zone before leaving the die hole. The outlet zone protects the sizing zone from crumbling. The exit cone angle prevents the drawn metal from bruising the exit of the sizing zone to ensure wire quality. The outlet zone should not be too short. Otherwise, the exit end of the die is prone to rupture. When manufacturing dies, the sharp edge of the connecting part between the outlet zone and the sizing zone should be ground away, so that the transition is made in a circular manner to prevent the wires from being bruised.

## USING NOTES OF DRAWING DIES

1. The shape and size of the die must be suitable for the material to be drawn. Otherwise, the die is easily broken.
2. The die must be correctly fastened along the stretching direction without skewing to prevent uneven wear.
3. Lubricant has a large impact on the service life of the die. Please lubricate the die in a clean condition with appropriate lubricant.
4. Please do not knock or fling the dies.



# CEMENTED CARBIDE COLD HEADING DIE BLANKS

# GRADE PROPERTIES

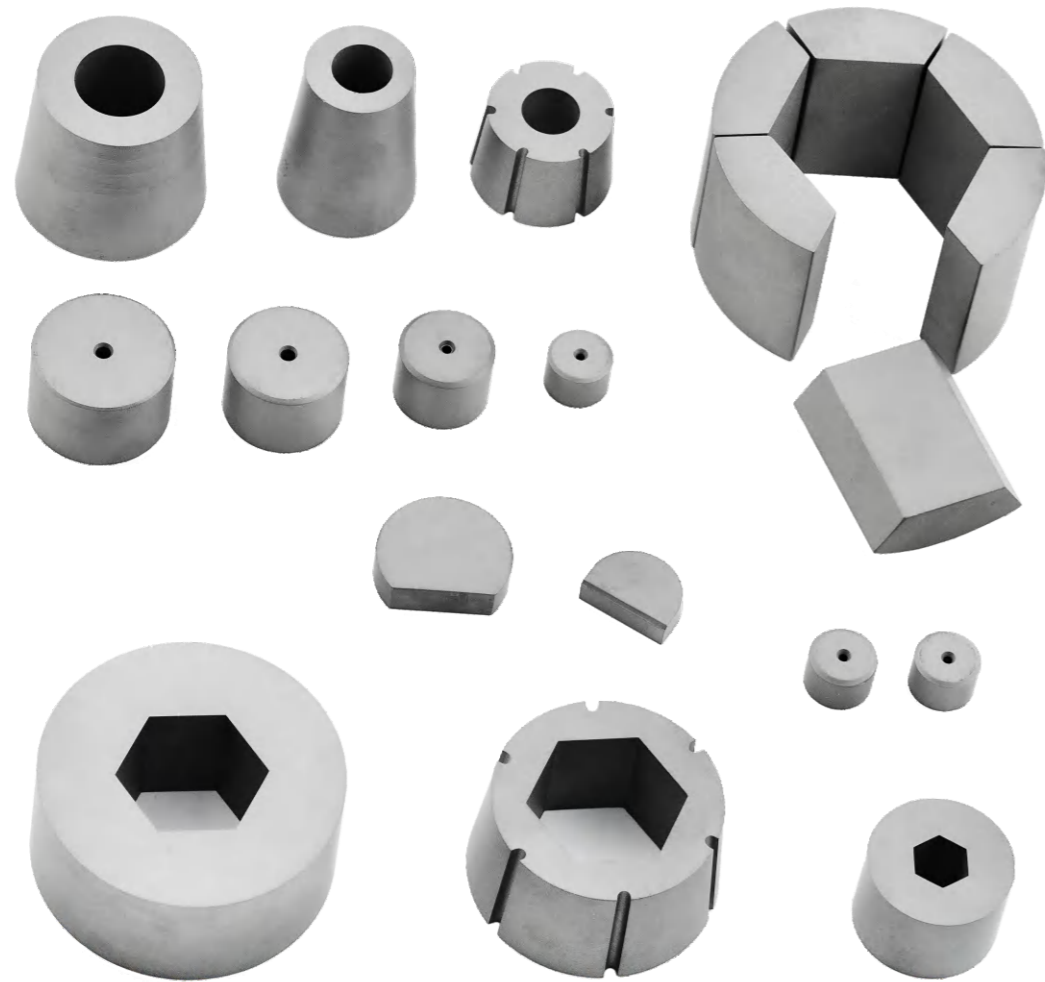

Product category	Grade	ISO grade	Co	WC	Density	Hardness		TRS
			wt%	μm	g/cm <sup>3</sup>	HRA	HV30	MPa
Classic grades	YG15	G30	14.9	1.6	14.06	87.2	1120	3200
	YG16C	G30	16.5	3.2	13.90	85.5	960	3000
	YG20C	G40	20	3.2	13.53	82.1	780	2600
	YG25	G50	25	1.6~2.0	13.10	81.7	720	3500
	YGH55	G60	26	3.2	13.00	81.5	680	2600
	YG27X	G55	27	1.2	12.95	84.0	870	3200
MB series grades	MB40	G20	14	2.4	14.10	87.5	1140	3200
	MB30	G30	16	2.0	13.85	88.0	1190	3600
	MB60	G40	20	2.4	13.55	84.4	850	2900
	MB52	G40	20	2.4	13.35	85.0	900	3000
	MB50	G50	22	1.6	13.40	85.6	970	3450
	MB66	G55	22	2.0	13.30	84.0	830	2850
	MB70	G50	25	2.4	13.10	82.0	730	2700
New grades	XF20T	K20-K40	10	0.6	14.40	92.3	1660	3600
	YG12X	K40	12	1.0~2.0	14.25	89.6	1350	3000
	YG15X	>K40	15	1.0	13.95	88.4	1240	3200

# APPLICATION

Product category	Grade	Application
Classic grades	YG15	Small screw punching dies for instruments, glasses, etc., and large screw punching dies, etc.
	YG16C	Hot extrusion of large low-carbon steel parts.
	YG20C	Wide applications, such as knurling, flanges, straight rod dies, low and medium carbon steel cutters, etc.
	YG25	With high impact toughness and fatigue strength. Applicable to screw dies with large impact force such as countersunk head.
	YGH55	Heavy-load screw and nut molds, such as large countersunk head molds.
	YG27X	Straight rod dies and nut forming dies of low and medium carbon steel, and alloy steel.
MB series grades	MB40	Low and medium carbon steel rod reducing dies, strong reducing dies.
	MB30	Steel ball dies, high wear-resistant dies.
	MB60	Straight rod dies and nut forming dies of low and medium carbon steel, and alloy steel.
	MB52	Screw dies for bundle rods and straight rods with large working load.
	MB50	Screw dies for bundle rods and straight rods with large working load.
	MB66	With excellent wear resistance and impact toughness. Applicable to bundle rods and straight rods, etc.
	MB70	With high impact toughness and fatigue strength. Applicable to screw dies with large impact force such as countersunk head.
New grades	XF20T	Dry drawing of tire cord, welding wire and high carbon wire.
	YG12X	Wear parts.
	YG15X	Low and medium carbon steel rod reducing dies, strong reducing dies.

## Classification and specification of cold heading die blank

**Type BD** heading die blanks for making standard bolts

**Type BF** heading die blanks for making hexagonal nuts

**Type BR** punching die blanks for making battey shells

The model of cold heading die blank is composed of category code, inner diameter, outer diameter and height. See example 1

example 1

**BD 0.7 × 10.0 × 12.0**

①            ②            ③            ④

- 1 Model category code of cold heading die blank.
- 2 The inner diameter dimension of cold heading die blank can round off to one decimal place at most, and the unit is mm.
- 3 The outer diameter dimension of cold heading die blank can round off to one decimal place at most, and the unit is mm.
- 4 The height dimension of cold heading die blank can round off to one decimal place at most, and the unit is mm.



# PRODUCT TYPES

## TYPE BD

HEADING DIE BLANKS FOR MAKING STANDARD BOLTS

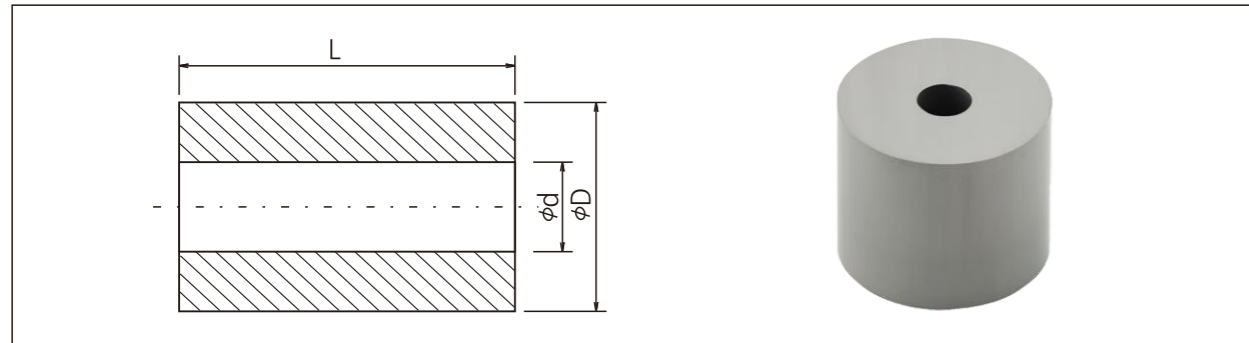

D	L	d
8	≤20	0.5~5.0
10	≤20	0.8~6.0
12	≤30	1.2~8.0
15	≤40	1.5~10.0
18	≤45	1.5~10.0
20	≤45	2.0~10.0
22	≤45	2.0~10.0
25	≤45	2.0~12.0
30	≤45	2.0~20.0
35	≤45	2.0~25.0
40	≤50	2.0~25.0
45	≤50	2.0~25.0
50	≤50	2.0~25.0
55	≤50	2.0~25.0
60	≤50	2.0~25.0
70	≤50	2.0~25.0

Other specifications can be customized

mm

# PRODUCT TYPES

## TYPE BF

HEADING DIE BLANKS FOR MAKING HEXAGONAL NUTS

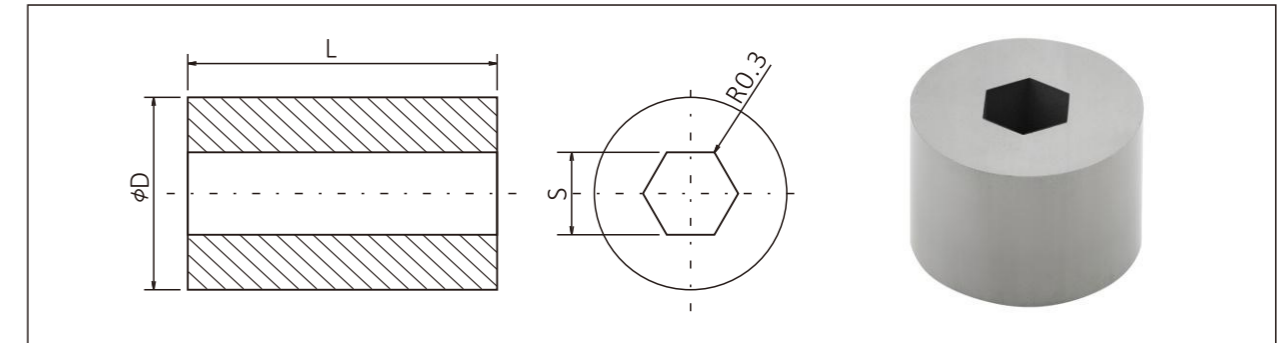

Type	S	D	L
BF8.2×26.0×28.0	8.2	26.0	28.0
BF11.2×26.0×28.0	11.2	26.0	28.0
BF13.2×26.0×28.0	13.2	26.0	28.0
BF16.2×40.0×30.0	16.2	40.0	30.0
BF19.0×40.0×30.0	19.0	40.0	30.0

Other specifications can be customized

mm

# PRODUCT TYPES

## TYPE BR

PUNCHING DIE BLANKS FOR MAKING BATTERY SHELLS

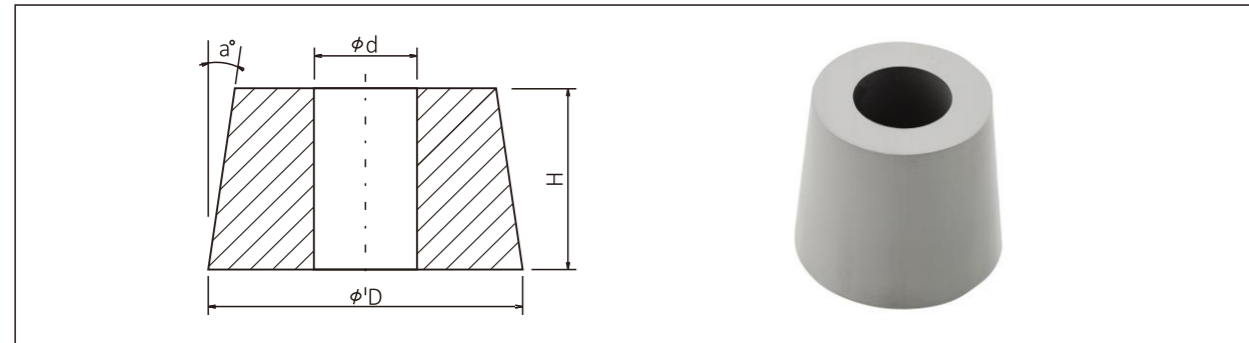

Type	d	D	H	$\alpha^\circ$
BR8.8×20.0×20.0	8.8	20.0	20.0	1°30'
BR9.5×20.0×20.0	9.5	20.0	20.0	1°30'
BR9.6×20.0×20.0	9.6	20.0	20.0	1°30'
BR13.0×25.0×20.0	13.0	25.0	20.0	1°30'
BR19.0×32.0×20.0	19.0	32.0	20.0	1°30'
BR22.5×38.0×20.0	22.5	38.0	20.0	1°30'
BR24.0×38.0×20.0	24.0	38.0	20.0	1°30'
BR24.5×38.0×20.0	24.5	38.0	20.0	1°30'
BR30.0×48.0×20.0	30.0	48.0	20.0	1°30'
BR30.8×47.0×20.0	30.8	47.0	20.0	1°30'
BR30.8×52.0×20.0	30.8	52.0	20.0	1°30'
BR31.8×47.0×20.0	31.8	47.0	20.0	1°30'
BR5.0×25.0×25.0	5.0	25.0	25.0	7°
BR6.0×33.0×30.0	6.0	33.0	30.0	7°
BR7.0×33.0×25.0	7.0	33.0	25.0	7°
BR8.0×46.0×60.0	8.0	46.0	60.0	7°
BR12.5×40.0×25.0	12.5	40.0	25.0	7°
BR14.0×30.0×25.0	14.0	30.0	25.0	7°
BR14.5×48.0×25.0	14.5	48.0	25.0	7°
BR16.0×34.0×25.0	16.0	34.0	25.0	7°
BR20.5×48.0×25.0	20.5	48.0	25.0	7°

Other specifications can be customized

mm

## Classification and specification of cold heading die blank

### Type BP combination die blanks for making hexagonal nuts

The model of cold heading die blank is composed of category code, arc radius, thickness and length. See example 2

#### example 2

**BP 11.0 × 6.0 × 27.0**

①      ②      ③      ④

- 1 Category code of hexagonal formwork.
- 2 The R dimension of the hexagonal die, with a maximum of one decimal place, is in mm.
- 3 The T dimension of the hexagonal die, with a maximum of one decimal place, is in mm.
- 4 The L dimension of the hexagonal die, with a maximum of one decimal place, is in mm.

### Type BG punching die blanks for making steel balls

The type BG cold heading die blank is composed of five parts: category code, spherical size, outer diameter, height and inner diameter. See example 3

#### example 3

**BG 4.0 × 10.0 × 10.0 × 0.9**

①      ②      ③      ④      ⑤

- 1 Category code of steel ball die.
- 2 Spherical dimension D1, with one decimal place at most, and the unit is mm.
- 3 The outer diameter dimension D, with one decimal at most, is in mm.
- 4 Height dimension h, with one decimal place at most, and the unit is mm.
- 5 The inner diameter dimension D, with one decimal at most, is in mm.



# PRODUCT TYPES

## TYPE BP

COMBINATION DIE BLANKS FOR MAKING HEXAGONAL NUTS

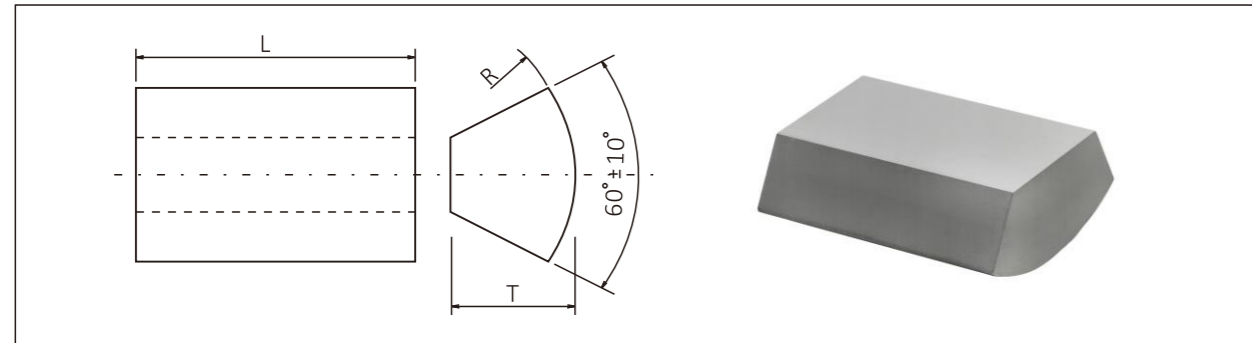

Type	R	T	L
BP11.0×6.0×21.0	11.0	6.0	21.0
BP11.0×7.0×13.0	11.0	7.0	13.0
BP12.0×7.2×16.5	12.0	7.2	16.5
BP15.0×8.0×20.0	15.0	8.0	20.0
BP18.0×9.0×29.0	18.0	9.0	29.0
BP18.0×10.0×29.0	18.0	10.0	29.0
BP20.0×10.5×28.0	20.0	10.5	28.0
BP23.0×11.0×33.0	23.0	11.0	33.0
BP23.0×12.5×33.0	23.0	12.5	33.0
BP25.0×13.0×32.0	25.0	13.0	32.0
BP25.0×14.0×28.0	25.0	14.0	28.0
BP25.0×14.0×32.0	25.0	14.0	32.0
BP27.5×14.0×36.0	27.5	14.0	36.0
BP30.0×14.0×42.0	30.0	14.0	42.0
BP30.0×15.0×42.0	30.0	15.0	42.0

Other specifications can be customized

mm

# PRODUCT TYPES

## TYPE BG

PUNCHING DIE BLANKS FOR MAKING STEEL BALLS

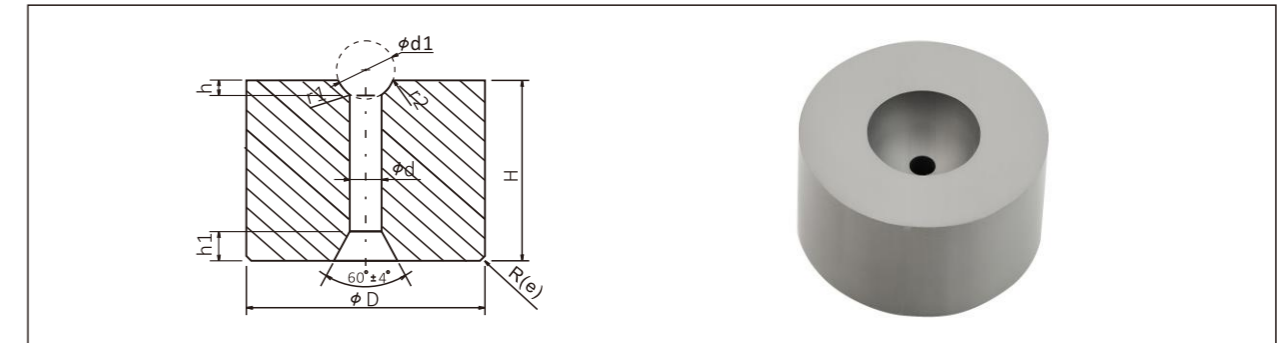

Type	d1	D	H	d	h	h1	r1	r2	R(e)
BG4.0×10.0×10.0×0.9	4.0	10.0	10.0	0.9	1.5	-	0.8	-	-
BG4.2×12.2×9.2×1.3	4.2	12.2	9.2	1.3	-	1.5	0.3	0.3	1×45
BG5.6×26.0×16.0×3.0	5.6	26.0	16.0	3.0	-	1.3	-	-	1×45
BG7.2×16.0×11.0×2.0	7.2	16.0	11.0	2.0	-	1.3	-	-	1×45
BG7.2×31.0×18.0×3.2	7.2	31.0	18.0	3.2	-	1.3	0.3	0.5	1×45
BG8.6×20.2×15.2×1.8	8.6	20.2	15.2	1.8	3.9	1.5	0.4	0.4	1.5
BG8.8×18.0×13.2×2.5	8.8	18.0	13.2	2.5	-	1.3	-	-	1×45
BG11.0×30.0×20.0×3.0	11.0	30.0	20.0	3.0	-	4.0	-	-	2×45
BG11.2×25.3×18.3×2.3	11.2	25.3	18.3	2.3	5.1	1.5	0.5	0.5	2
BG11.2×30.3×20.3×2.8	11.2	30.3	20.3	2.8	5.1	1.5	0.5	0.5	2
BG12.0×30.3×20.3×2.8	12.0	30.3	20.3	2.8	5.5	1.5	0.5	0.5	2
BG12.2×28.0×16.0×3.0	12.2	28.0	16.0	3.0	-	1.3	-	-	1×45
BG14.5×30.3×20.3×2.8	14.5	30.3	20.3	2.8	6.7	1.5	0.5	0.5	2
BG15.2×35.4×25.4×3.3	15.2	35.4	25.4	3.3	7.9	1.5	0.5	0.5	2
BG16.0×35.4×25.4×3.3	16	35.4	25.4	3.3	7.3	1.5	0.5	0.5	2

Other specifications can be customized

mm

# PRODUCT TYPES

## TYPE HQB BLANKS FOR CUTTING

### Classification and specification of cold heading die blank

#### Type HQB blanks for cutting

The type HQB cold heading die blank is composed of category code, width, length and height.  
See example 4

##### example 4

**HQB 10.0 × 10.0 × 3.5**

①                  ②                  ③                  ④

- 1 Cutter category code.
- 2 Width dimension, with one decimal at most, and the unit is mm.
- 3 Length dimension, with one decimal at most, and the unit is mm.
- 4 Height dimension, with one decimal at most, and the unit is mm.

#### Type HQY blanks for cutting

The model of cold heading die blank is composed of category code, inner arc diameter, width, length and height. See example 5

##### example 5

**HQY 2.0 × 10.0 × 12.0 × 1.0**

①                  ②                  ③                  ④                  ⑤

- 1 Cutter category code.
- 2 The diameter dimension of the inner arc can round off to one decimal place at most, and the unit is mm.
- 3 Width dimension, with one decimal at most, and the unit is mm.
- 4 Length dimension, with one decimal at most, and the unit is mm.
- 5 Height dimension, with one decimal at most, and the unit is mm.

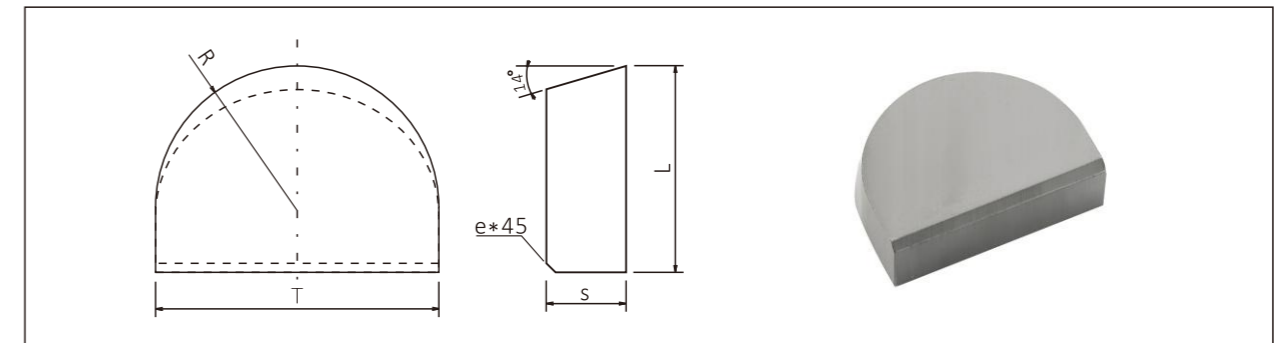

Type	T	L	S	R	e
HQB10.0×10.0×3.5	10.0	10.0	3.5	5.0	-
HQB12.0×12.0×4.5	12.0	12.0	4.5	6.0	0.8
HQB16.0×14.0×5.0	16.0	14.0	5.0	8.0	0.8
HQB20.0×16.0×6.0	20.0	16.0	6.0	10.0	0.8
HQB25.0×20.0×7.0	25.0	20.0	7.0	12.5	0.8
HQB30.0×25.0×8.0	30.0	25.0	8.0	15.0	0.8

Other specifications can be customized

mm



# PRODUCT TYPES

TYPE HQY  
BLANKS FOR CUTTING

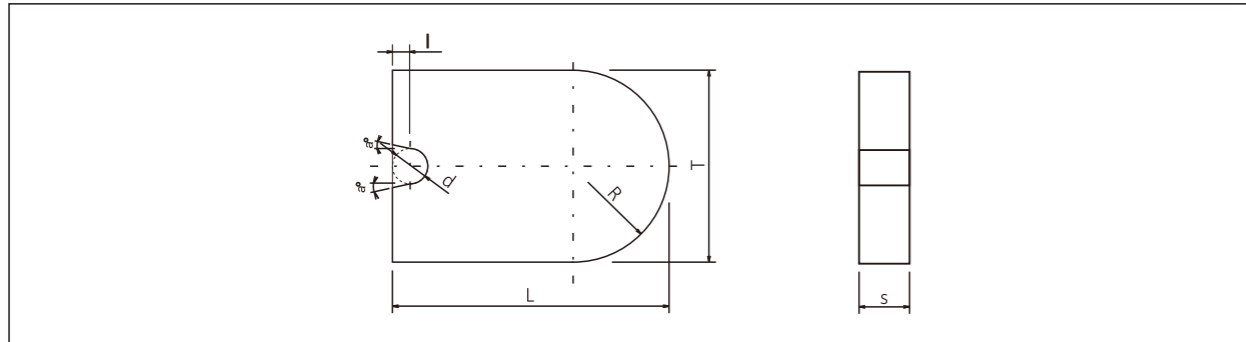

Type	d	T	L	S	l	R	$\alpha^\circ$
HQY2.0×10.0×12.0×1.0	2.0	10.0	12.0	1.0	-	5.0	-
HQY3.4×16.0×16.0×2.5	3.4	16.0	16.0	2.5	-	8.0	-
HQY4.0×25.0×25.0×3.0	4.0	25.0	25.0	3.0	5.0	12.5	5
HQY4.6×16.0×16.0×4.0	4.6	16.0	16.0	4.0	-	8.0	-
HQY5.4×16.0×16.0×5.0	5.4	16.0	16.0	5.0	-	8.0	-
HQY6.4×10.0×12.0×2.0	6.4	10.0	12.0	2.0	-	5.0	-
HQY6.4×16.0×16.0×5.0	6.4	16.0	16.0	5.0	-	8.0	-
HQY8.0×25.0×25.0×4.5	8.0	25.0	25.0	4.5	5.0	12.5	5
HQY8.0×30.0×30.0×6.0	8.0	30.0	30.0	6.0	5.0	15.0	5
HQY8.4×22.0×22.0×5.5	8.4	22.0	22.0	5.5	-	11.0	-
HQY9.4×22.0×22.0×8.0	9.4	22.0	22.0	8.0	-	11.0	-
HQY10.0×30.0×30.0×10.0	10.0	30.0	30.0	10.0	3.0	15.0	6
HQY14.0×36.0×35.0×13.0	14.0	36.0	35.0	13.0	3.0	15.0	6

Other specifications can be customized

mm

# CEMENTED CARBIDE BLOCKS FOR MOULD MAKING

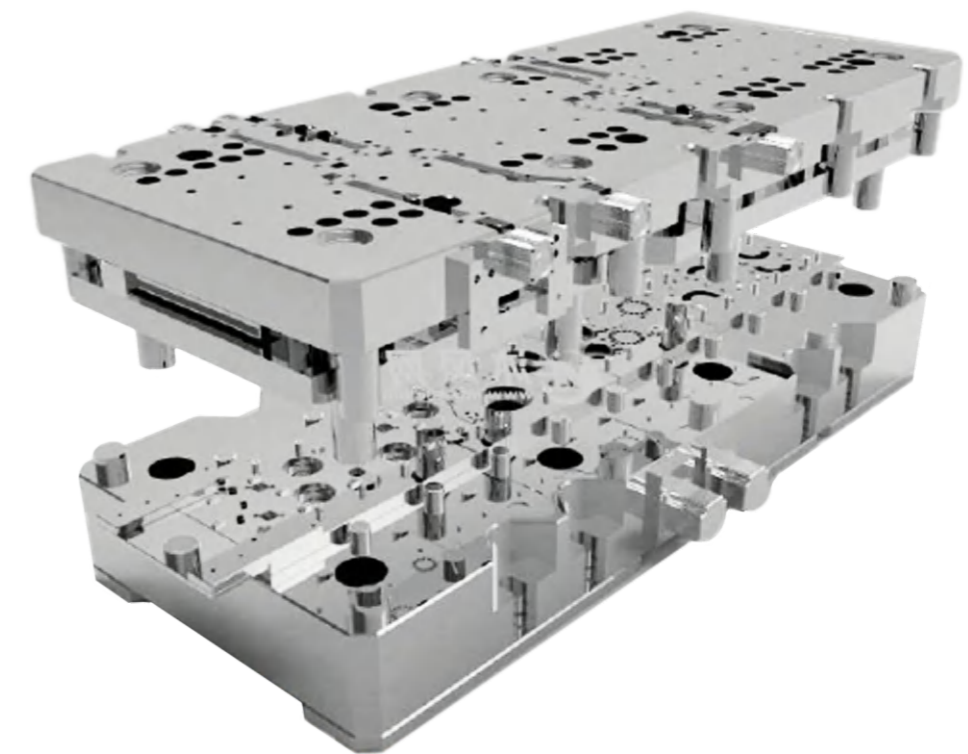

# GRADE PROPERTIES

Grade series	Grade	ISO grade	Grain size	Co	Density	Hardness		TRS
			μm	wt%	g/cm <sup>3</sup>	HRA	HV30	MPa
Electronic progressive press series	XF20S	K20	0.6	10	14.40	92.0	1640	3800
	YL10.2	K20-K40	0.8	10	14.45	91.5	1570	3600
	MZ25	K30-K40	1.5	12	14.12	90.5	1450	3200
	MJ20S	K40	0.8	13.5	14.10	90.3	1430	3800
	MJ18S	K20-K40	0.6	15	13.88	90.2	1420	3800
Motor progressive press series	MZ25S	K40	1.0	12	14.12	90.5	1450	3800
	MZ30	K40	1.2	12	14.15	89.7	1370	3500
	MZ40	>K40	1.2	15	13.90	88.5	1240	3800
	MZ50	G40	2.0	20	13.40	86.2	1030	3450
Classic series	YG8	G15	1.6	8	14.75	89.9	1390	3000
	YG11	G20	1.6	11	14.45	88.0	1190	3200
	YG15	G30	1.6	15	14.05	87.0	1100	3300
	YG20	G40	1.6	20	13.55	85.0	920	3400
Extensioend series	YG6	K10	1.6	6	14.95	90.5	1450	2800
	YG6X	K10/G10	0.8	6	14.92	92.5	1640	2400
	KU30F	K20-K40	0.6	9.5~10.0	14.37	92.1	1620	3800
	YG25C	G50	2.4	25	13.51	82.0	739	3980

Note: Density, hardness and TRS ( Transverse rupture strength ) are typical values

# APPLICATION

Grade series	Grade	Application
Electronic progressive press series	XF20S	Pressing thin sheets of stainless steel, copper and aluminum (less than 0.2mm) at high speed.
	YL10.2	Producing low-and-medium-speed electronic progressive concave and convex dies, suitable for pressing thin sheets of copper alloy and aluminum.
	MZ25	Suitable for electronic progressive convex and concave dies for pressing.
	MJ20S	Good versatility. Producing precision lead frame, convex and concave dies for pressing. Suitable for stamping copper, aluminum and stainless steel thin sheets (less than 0.4mm) at medium and high speed.
	MJ18S	Good versatility. Producing connector, convex and concave dies for pressing. Suitable for stamping copper, aluminum and stainless steel thin sheets (less than 0.4mm) at medium and high speed.
Motor progressive press series	MZ25S	Good versatility. Producing motor progressive concave and convex pressing dies.
	MZ30	Good versatility. Producing motor progressive dies for pure iron and silicon steel sheets.
	MZ40	Particularly suitable for concave and convex dies for cold rolled sheets and silicon steel sheets.
	MZ50	Suitable for thick plates under large impulsive load, and progressive concave dies and compound dies in complex shapes.
Classic series	YG8	Producing concave and convex dies for general motors, electronics and powder metallurgy.
	YG11	Producing precision pressing convex and concave dies, suitable for pressing copper and aluminum.
	YG15	Producing concave and convex dies for general motors, electronics and powder metallurgy.
	YG20	Producing concave and convex dies under large impulsive loads for motors, electronics and powder metallurgy.
Extensioend series	YG6	Popular grade for mining tips, construction application and blades, etc. Extended grade for YG8 with higher wear resistance.
	YG6X	Extended grade for YG6 with higher wear resistance, less breakage risk.
	KU30F	Extended grade for YL10.2 with higher corrosion resistance.
	YG25C	Extended grade for YG20 with higher toughness but less wear resistance.



# ELECTRONIC PROGRESSIVE PRESS SERIES

L (mm)	B (mm)	H (mm)	Tolerance		
			Sintered block		
			L	B	H
100	100	1~70	0~+2.0	0~+2.0	0.3~+0.6
105	105	1~70	0~+2.0	0~+2.0	0.3~+0.6
120	120	3~70	0~+2.0	0~+2.0	0.3~+0.6
150	150	3~80	0~+3.0	0~+3.0	0.3~+0.6
200	200	5~80	0~+3.0	0~+3.0	0.3~+0.6
250	250	8~45	0~+3.0	0~+3.0	0.3~+0.6
300	300	10~30	0~+3.0	0~+3.0	0.3~+0.6

Other specifications can be customized

mm

# MOTOR PROGRESSIVE PRESS SERIES

L (mm)	B (mm)	H (mm)	Tolerance		
			Sintered block		
			L	B	H
100	50	25	0~+1.5	0~+1.5	+0.3~+0.6
	60	25/40	0~+1.5	0~+1.5	+0.3~+0.6
	72	50	0~+1.5	0~+1.5	+0.3~+0.6
	85	25	0~+1.5	0~+1.5	+0.3~+0.6
	100	10~80	0~+1.5	0~+1.5	+0.3~+0.6
105	105	10~70	0~+2.0	0~+2.0	+0.3~+0.6
150	150	10~70	0~+2.0	0~+2.0	+0.3~+0.6
200	200	10~30	0~+3.0	0~+3.0	+0.3~+0.6
300	300	10/20	0~+3.0	0~+3.0	+0.3~+0.6

Other specifications can be customized

mm

## BLOCKS MACHING TIPS

### Grinding comparison of partial grades

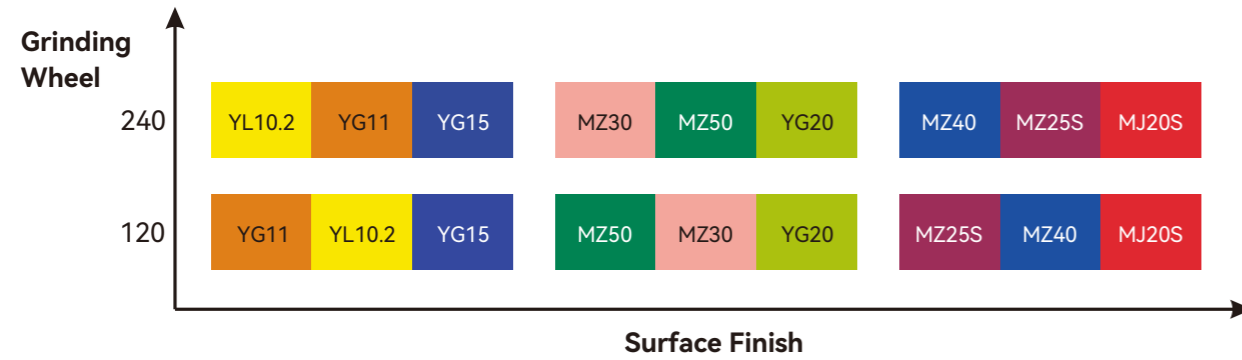

### Processing notes:

1. Different strategies should be adopted when processing alloys with different micro-structures.
2. Alloys with medium and low bonded phases can be ground several times before being repeatedly refined with fine grinding wheel .
3. Medium and coarse grain alloys should be processed with fine avoidance of larger wheel feeds to avoid damage to the alloy matrix caused by grinding wheel compressive stress.
4. Processing selection: double crystal structure of the alloy should be selected to cut a repair three ways to process, single crystal can be used fast wire open piece after grinding processing.

## Electronic progressive stamping series-Lead frame and electronic connector stamping materials

In order to improve market competitiveness and solve problems including stress cracking, non-wear resistance, chipping, and sharp edges, ZCC set up a professional team to match top world players. Based on years of technical achievements in R&D and production of sheets, ZCC developed a new generation of cemented carbide, material structures of which are much better than before. In addition, with a better mastery of defects, the materials' uniformity, toughness, and wear-resistance are also comprehensively improved. We subdivide application scenarios to guarantee material stability during processing, thus enhancing product longevity.

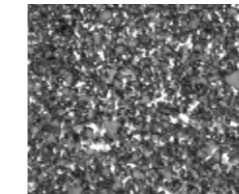

#### MJ20S

Ultra-fine grain, high toughness, high hardness, superior wear resistance and impact resistance, and sharp edge. Suitable for high-speed precision pressing of brass, copper, SPCC and thin stainless steel, etc. Excellent versatility.

#### MZ25

Medium grain, high toughness, impact resistance, high hardness, and good wear resistance. Suitable for high-speed pressing of brass, copper, SPC and thin stainless steel, etc. Good versatility.

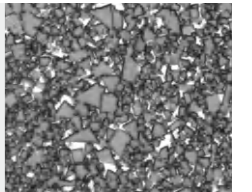

## Motor progressive pressing series-motor core pressing material

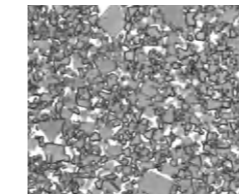

#### MZ25S

Ultra-high toughness in structure design, fine grain size, high hardness, and superior wear resistance. Suitable for medium-and-high-speed precision pressing of SPCC, silicon steel sheets and other materials. Good versatility.

#### MZ30

Synergistic structure with high toughness and corrosion resistance , high hardness, and good wear resistance. Applicable to motor stator and rotor silicon steel sheets, silicon steel sheets, SPCC pressing, as well as medium-and-high-speed pressing of copper alloy, among other materials, with good versatility.

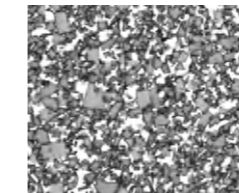
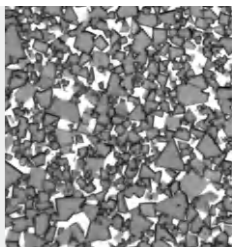

#### MZ40

Synergistic structure with high toughness, corrosion resistance excellent wear resistance, and impact resistance. Especially suitable for medium-and-high-speed pressing of silicon steel sheets, SPCC, and so on.. Good versatility.

#### MZ50

High impact toughness. Especially suitable for low-speed pressing of thick silicon steel sheets, and SPCC under large impulsive load.

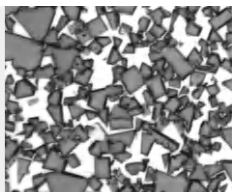



## MECHANICAL & PHYSICAL PROPERTIES OF CEMENTED CARBIDE

### GRADE REFERENCE

ISO code	ZCC	KYORITSU	KENAMETAL	CERATIZIT
K40	MU20S	KD20/WD20	CD650	CF-H40S
K40	MZ25	KD20	-	CF-H40S+
K40	XF20S	KD10	MG18	CTS20
K20-K40	YL10.2	KD10	KF310	TSM30/CTS20
K40	MZ25S	KN20	KR466	CF-H40S+
K40	MZ30	G4	CD650	CF-H40S
>K40	MZ40	TB6	K3109	B40S
G20	YG11	G5	K92	GC30/H50S
G30	YG15	TB6	K3109	CTM30
G40	YG20/MZ50	TB7	K91	CTM40

**Density:** Referring to the mass per unit volume. It generally decreases as the proportion of the binding phase increases.

**Hardness:** Referring to material's ability to resist elastic deformation, plastic deformation or damage. It generally decreases as the proportion of the binding phase increases.

**Transverse rupture strength:** Referring to the material's ability to resist bending and prevent fracture. It generally increases as the proportion of the binding phase increases.

**Fracture toughness:** Referring to material's ability to prevent crack expansion due to instability. It generally increases as the proportion of binding phase increases.

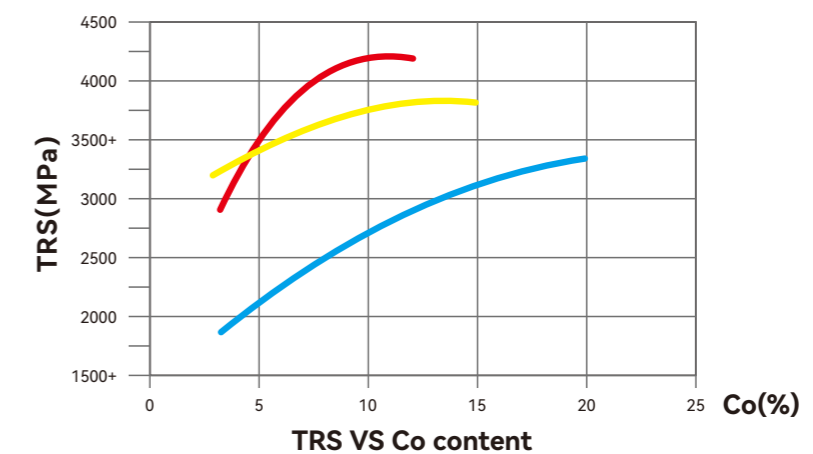
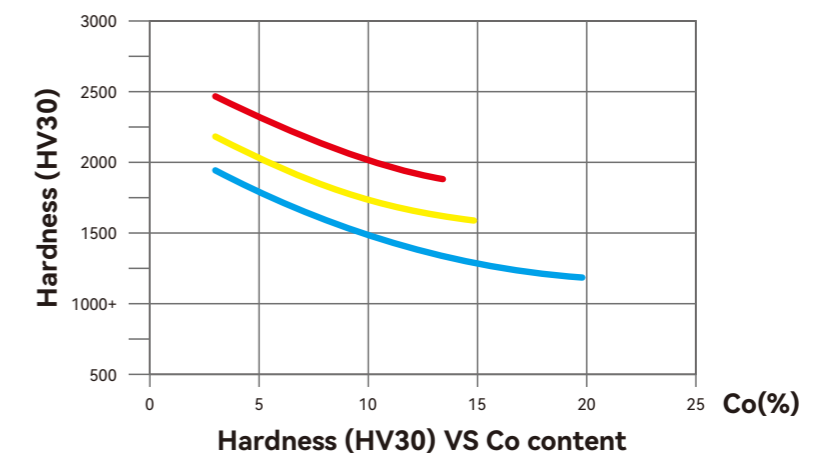

— Fine/medium grain      — Submicron grain      — Coarse grain



# SOCIAL RESPONSIBILITY

Focusing on the new development landscape featuring carbon peaking, carbon neutrality, and dual circulation, China Minmetals actively expands new standards, new technology, green energy, and digital intelligence, and continuously promotes intelligent, efficient, green and low-carbon development. It creates a more optimized lifestyle, and contributes to China's high-quality and sustainable development.

ZCC Group has been once again recognized as an environmental credit and integrity enterprise in Hunan Province. In accordance with people-orientated management philosophy, ZCC empowers the staff, provides quality service for customers and makes contributions to building a harmonious society. ZCC is dedicated to the development of staff, enterprise and society.

Aimed at becoming an environmental-friendly enterprise, ZCC implemented clean production and promoted environmental protection by eliminating its energy-intensive production lines and introducing new technologies, new processes and new energy resources. In May 2011, the natural gas boiler system went into operation, and the last two chimneys were removed.



# WORLDWIDE SALES NETWORK



ZCC adopts international business strategy. Sales branches in Germany, the US, etc. were successively set up. Products of ZCC are exported to more than 70 countries and regions around the world. Adhering to the brand position of "first in China, first-class in the world", ZCC has become a reliable business partner of world-renowned enterprises, such as Schlumberger and Kennametal, through business cooperation and technology development. ZCC constantly strengthens itself by shaping brand, and fully integrates international resources including brand, technology, channels, and culture.

Looking ahead, ZCC is committed to the rejuvenation of China's tungsten industry. Bearing in mind the spirit of "pursuing excellence with relentless efforts", ZCC will create a cemented carbide group that is "first in China, first-class in the world" by constantly improving its technological innovation capacity and playing a leading role in the industry.

## U.S.A

**Zhuzhou Cemented Carbide Works USA Inc.**  
4651 Platt Lane Ann Arbor, MI 48108, USA.

TEL: +1-734-302-0125  
FAX: +1-734-302-0126  
EMAIL: [info@zccamerica.com](mailto:info@zccamerica.com)

## Europe

**ZCC Europe GmbH**  
Wanheimer Str. 59, 40472 Dusseldorf, Germany.

## HK,China

**Zhuzhou Cemented Carbide Group HongKong Co.,Ltd.**  
Flat E, 19/F, Block 4, Nam Fung Sun Chuen, 38 Greig Road, Quarry Bay, Hong Kong, China.